

**Agricultural productivity in New  
Zealand: First estimates from the  
Longitudinal Business Database**

**Eyal Apatov, Richard Fabling, Adam Jaffe,  
Michele Morris, & Matt Thirkettle**

**Motu Working Paper 15-13  
Motu Economic and Public Policy Research**

**September 2015**



## Author contact details

Eyal Apatov  
Motu Economic and Public Policy Research  
[eyal.apatov@motu.org.nz](mailto:eyal.apatov@motu.org.nz)

Richard Fabling  
Independent Researcher  
[richard.fabling@xtra.co.nz](mailto:richard.fabling@xtra.co.nz)

Adam Jaffe  
Motu Economic and Public Policy Research  
[adam.jaffe@motu.org.nz](mailto:adam.jaffe@motu.org.nz)

## Acknowledgements

This research was prepared with funding from the Kelliher Charitable Trust and the New Zealand Productivity Hub, which are gratefully acknowledged. Richard Fabling and Michele Morris also thank the Ministry for the Environment for funding their preliminary work on this topic. The authors thank Suzi Kerr for securing funding for the agricultural data linking, Dave Maré for feedback and assistance, Statistics New Zealand for data access, and staff from the Ministry for the Environment and the Ministry of Primary Industries for their valuable feedback.

## Disclaimer

The results in this paper are not official statistics, they have been created for research purposes from the Integrated Data Infrastructure (IDI) managed by Statistics New Zealand. The opinions, findings, recommendations and conclusions expressed in this paper are those of the authors not the Kelliher Charitable Trust, Productivity Hub, Ministry for the Environment, Statistics NZ, or Motu.

Access to the anonymised data used in this study was provided by Statistics NZ in accordance with security and confidentiality provisions of the Statistics Act 1975. Only people authorised by the Statistics Act 1975 are allowed to see data about a particular person, household, business or organisation and the results in this paper have been confidentialised to protect these groups from identification.

Careful consideration has been given to the privacy, security and confidentiality issues associated with using administrative and survey data in the IDI. Further detail can be found in the privacy impact assessment for the IDI available from [www.stats.govt.nz](http://www.stats.govt.nz).

The results are based in part on tax data supplied by Inland Revenue to Statistics NZ under the Tax Administration Act 1994. This tax data must be used only for statistical purposes, and no individual information may be published or disclosed in any other form, or provided to Inland Revenue for administrative or regulatory purposes. Any person who has had access to the unit-record data has certified that they have been shown, have read, and have understood section 81 of the Tax Administration Act 1994, which relates to secrecy. Any discussion of data limitations or weaknesses is in the context of using the IDI for statistical purposes, and is not related to the data's ability to support Inland Revenue's core operational requirements.

## Motu Economic and Public Policy Research

PO Box 24390  
Wellington  
New Zealand

Email [info@motu.org.nz](mailto:info@motu.org.nz)  
Telephone +64 4 9394250  
Website [www.motu.org.nz](http://www.motu.org.nz)

© 2015 Motu Economic and Public Policy Research Trust and the authors. Short extracts, not exceeding two paragraphs, may be quoted provided clear attribution is given. Motu Working Papers are research materials circulated by their authors for purposes of information and discussion. They have not necessarily undergone formal peer review or editorial treatment. ISSN 1176-2667 (Print), ISSN 1177-9047 (Online).

## **Abstract**

Exports of dairy and sheep/beef products account for over 40% of New Zealand's aggregate merchandise exports. As a consequence, the performance of farms in these industries has a significant impact on the New Zealand economy. In this study, we link financial and agricultural data from the New Zealand Longitudinal Business Database (LBD) to estimate production functions of dairy and sheep/beef firms in New Zealand. Overall, we find that the data enables us to explain much of the industry-level variation in productivity and output, offering greater flexibility and insight than simply examining the official (aggregated) statistics. We find that variation in output can be largely explained by variation in capital, labour, intermediate expenditure, and productive land. We also find differences across industries in the way various farm practices (e.g. stocking rates, fertilizer use, supplementary activities, etc.) and area characteristics (including weather) relate to output. Finally, we find that estimating firm productivity at the industry level is less likely to accurately model the relationships for some sub-groups of firms (e.g. firms with different land size). We believe that our methodology could be useful for future studies addressing research questions relevant to this sector.

## **JEL codes**

D22; Q12; R30

## **Keywords**

Firm-level productivity; dairying; sheep-beef farming; Translog; fixed effects

## Contents

1.	Introduction and summary .....	7
2.	Model and estimation .....	8
3.	Data, population, and variables .....	10
3.1.	Sources.....	10
3.2.	Sample population .....	11
3.3.	Variables .....	12
4.	Descriptive statistics .....	13
5.	Results .....	17
5.1.	Results by industry.....	17
5.1.1.	Dairy.....	17
5.1.2.	Sheep/beef.....	18
5.2.	Productivity.....	19
5.2.1.	Industry level trends .....	19
5.2.2.	Time-invariant differences in productivity between regional councils.....	21
6.	Robustness tests .....	22
6.1.1.	Structure of firm productivity term .....	22
6.1.2.	Employment composition .....	23
6.1.3.	Output elasticities for firm with different land size .....	24
7.	Conclusions.....	25
8.	References .....	26
9.	Appendix .....	28
9.1.	Appendix 1 – Representativeness of the sample.....	28
9.1.1.	Sample construction .....	28
9.1.2.	Comparison to sources.....	30
9.2.	Appendix 2 – variables and sources .....	34
9.3.	Appendix 3 – Further descriptive analysis .....	35
9.3.1.	(Partial) productivity trends .....	35
9.3.2.	Regional trends.....	36
9.4.	Appendix 5 – MFP trends by industry and regional council.....	47

## Tables and figures

Table 1 - Output changes between industries, 2002/2007/2012.....	14
Table 2 - Descriptive statistics .....	15
Table 3 - Output elasticities by land quartile, by industry.....	25
Table 4 - Overall firm count in sample using different defining criteria.....	29
Table 5 - Summary statistics for selected variables, by source.....	31
Table 6 - Regression results, Dairy.....	39
Table 7 - Regression results, Sheep/Beef.....	42
Table 8 - Regression results, by industry and employment composition .....	45
Figure 1 - Schematic of firm structures (left) and geospatial linking (right) .....	11
Figure 2 - Distribution of firms by number of appearances in the sample.....	14
Figure 3 - Kernel density, Production function inputs and output.....	16
Figure 4 – Annual MFP changes by industry, 2002 – 2012.....	20
Figure 5 - Long-term/permanent regional differences in MFP.....	21
Figure 6 – Distribution of predicted gross output across models.....	24
Figure 7 - Graphical representation of the sample and sources .....	28
Figure 8 - Firm count by year and dataset, 2002-2012.....	32
Figure 9 - Kernel density, for selection of variables by source .....	33
Figure 10 – Output-to-input ratios, 2002 – 2012.....	35
Figure 11 – Dairy share of regional production in dairy and sheep/beef, 2002 - 2012 ....	36
Figure 12 - output per hectare by region and industry, 2002 and 2012.....	38
Figure 13 – Annual changes in MFP by regional council, dairy industry .....	47
Figure 14 - Annual changes in MFP by regional council, sheep/beef industry .....	47

## 1. Introduction and summary

Accounting for over 40% of total merchandise exports (Statistics New Zealand, 2011a), the agricultural sector plays a key role in the New Zealand economy. Not only is agriculture the primary source of employment in many rural areas, its performance also influences the success of urban regions (Grimes and Hyland, 2013) and its commodities are key inputs to many secondary industries. Therefore, an understanding of the different drivers of its output and productivity is important not only to the success of this sector, but also that of the greater economy.

In this study, we estimate the production function for two key agricultural industries – dairy and sheep/beef – which account for about two-thirds of New Zealand’s agricultural exports. By linking agricultural and financial firm-level data from New Zealand’s Longitudinal Business Database (LBD), we are able to quantify the relationships between different financial, agricultural and geospatial inputs and output. Estimating production functions using firm data with two-way fixed effect, second order Translog models allows us to account for differences both across and within industries (e.g. firm size) and geographies (i.e. regional councils) when exploring variations in output and of multifactor productivity (MFP) trends for each industry (both at the national and regional council levels).

Our results suggest that, matched firm-level data is adequate for estimating productivity in the different industries. In terms of variation in output, we find that the majority of variation can be explained by the four main production function inputs – capital, labour, intermediate expenditure, and productive land. Introducing additional controls does not improve the fit significantly, but is still useful as it quantifies (at a more detailed level) the dollar increase in output associated with different farming practices, location choices and firm characteristics.

Our results also stress differences in the role different inputs have across industries. For example, dairy farms achieve the greatest benefit from concentrating production in their primary activity (e.g. greater density of herd, greater application rates of fertilisers). Sheep/beef farms, however, also benefit from the addition of non-primary activities (e.g. producing dairy output, forestry work, etc.) and seem to be less sensitive to differences in land conditions. Exploring changes in MFP, we find that the average MFP in the dairy industry increased more rapidly than in the sheep/beef industry between 2002 and 2008, and more slowly thereafter, following a sharp decline in 2009. Furthermore, large differences in MFP were recorded across regional councils.

Overall, we find that linking different sources at the firm level explains much of the industry- level variation in productivity and offers greater flexibility and insight than simply examining the official (aggregated) statistics. The data suggest that firms are quite heterogeneous on both their activities and

in their resultant productivity; thus estimating firm productivity at the industry level is less likely to accurately model productivity for some sub-groups of firms (e.g. firms with different land size).

Future studies could build on our work by introducing behavioural or structural elements, or examining how management practices or workforce characteristics (e.g. age, qualifications, etc.) are related to firm productivity. In addition, our methodology could be used as a base to address other questions relevant to this sector (e.g. land conversions to dairy farming).

The rest of the study is organised as follows. Conceptual model and empirical strategy are outlined in section 2. Data sources, variables, and study sample are described in Section 3. Descriptive statistics are presented in section 4. The main production function estimates and productivity trends are presented in section 5, with the robustness of our models tested in section 6. Finally, section 7 summarises the main findings and notes the limitation of the research.

## 2. Model and estimation

In our conceptual model, output is some homogenous physical quantity, produced by combining a number of highly-aggregated inputs:

$$\text{Output} = f(\text{Capital}, \text{Labour}, \text{Intermediate Input}, \text{Land}, \text{Productivity})$$

For example, in the dairy industry, output is equal to litres of milk or kilograms of milk solids produced. Capital includes depreciation and rent on tractors, irrigation systems and fencing. Labour includes is the sum of employees and working proprietors. Intermediate expenditure includes use of fertiliser, diesel, electricity, wormicide and grass seeds; and land includes the total sum of land utilised for production. Productivity is a composite term that explains movements in output not explained by capital, labour, expenditure or land. It includes unexpected shocks, trends in the economic environment and the inherent quality of each farm and/or its managers.

To estimate our conceptual model, we take advantage of the existence of large, representative, farm-level panels, and apply an augmented second order gross output Translog production function (Christensen, Jorgenson, and Lau 1973):<sup>1,2</sup>

---

<sup>1</sup> The advantage of estimating the data with a Translog model is that the different inputs are able to have a non-linear relationship with output, and complement one another. We also applied a Cobb-Douglas model, yielding similar results.

<sup>2</sup> For a general review of estimating productivity using the production functions, see Van Beveren (2012). For more information regarding the estimation of productivity via the production function in New Zealand, see Fabling and Mare (2015). For criticisms of this approach, and alternative approaches, see Griliches and Mairesse (1998), Olley and Pakes (1996), Levinsohn and Petrin (2003), Akerberg, Caves, and Frazer (2006), and Wooldridge (2009).

$$\begin{aligned}
Y_{i,t} = & \beta_0 + \beta_k K_{i,t} + \beta_l L_{i,t} + \beta_m M_{i,t} + \beta_p P_{i,t} + \beta_{kk} K_{i,t}^2 + \beta_{ll} L_{i,t}^2 + \beta_{mm} M_{i,t}^2 + \beta_{pp} P_{i,t}^2 \\
& + \beta_{kl} K_{i,t} L_{i,t} + \beta_{km} K_{i,t} M_{i,t} + \beta_{kp} K_{i,t} P_{i,t} + \beta_{lm} L_{i,t} M_{i,t} + \beta_{lp} L_{i,t} P_{i,t} + \beta_{mp} M_{i,t} P_{i,t} \\
& + \sum_j \beta_j X_{i,t} + \zeta_i + \psi_t + \varepsilon_{i,t}
\end{aligned}$$

Where  $it$  denotes a farm-time observation. Farm output ( $Y_{i,t}$ ), capital ( $K_{i,t}$ ), labour ( $L_{i,t}$ ), intermediate expenditure ( $M_{i,t}$ ), and productive land ( $P_{i,t}$ ) are all measured in natural logarithms. In addition, we augment the production function by including additional farm-level inputs and area and firm characteristics ( $X_{i,t}$ ). ( $\beta_0$ ) is a constant term, capturing the overall time-firm mean productivity and inputs level. We assume that productivity is farm and time separable, with ( $\zeta_i$ ) capturing the farm specific time-invariant productivity, and ( $\psi_t$ ) capturing temporal changes in productivity across all firms. Finally, ( $\varepsilon_{i,t}$ ), is the error term, capturing exogenous shocks.<sup>3</sup>

Financial inputs and output are measured by their real dollar value (rather than using service units), assuming that this accounts for differences in quality. That is, we assume that, ceteris paribus, higher quality outputs will tend to sell for more. Real values for these inputs are derived by deflating monetary variables by their most relevant Producer Price Index.<sup>4</sup>

We estimate the various relationships between inputs and output, and derive MFP trends at the industry level using various specifications, including a number of regional models.<sup>5</sup> These models enable us to both derive MFP estimates at the sub-national level, and to test our assumption regarding the structure of productivity.

Finally, we test the ability of our model to account for firm heterogeneity by comparing the estimated productivity using our benchmark model with those estimated separately for farms with different land size and employment composition.

---

<sup>3</sup> We correct for possible autocorrelation by using year effects, while logging all continuous variables and using robust standard errors (clustered by firms) should reduce any heteroscedasticity.

<sup>4</sup> Deflating firm-level inputs and output with industry level deflators could result in an omitted price bias. However, we expect prices (in both markets) to be similar across firms in the New Zealand agricultural industry. This is due to three main reasons. Firstly, approximately 95% of meat and dairy output produced is exported (Statistics New Zealand, 2011) and thus subject to world prices. Secondly, the vast majority of the industry is comprised of small enterprises (e.g. Statistics New Zealand's Business Demography Statistics show that in 2014, over 94% of enterprises had five or less workers), which are less likely to be price makers. Third, agricultural output for the examined industries is fairly homogenous.

<sup>5</sup> In the regional models, region fixed effects replace firm fixed effects. These fixed effects are based on the location of the firm in one of the sixteen regional councils, as defined in Statistics New Zealand (2015).

### 3. Data, population, and variables

#### 3.1. Sources

Most data are sourced from Statistics New Zealand's Longitudinal Business Database (LBD). This database is a rich source of administrative and survey data for all economically significant businesses in the New Zealand economy.<sup>6</sup> The productivity variables come from tax returns (IR10s) and Linked Employee-Employer data (LEED). Information about firm age, location, and industry is taken from the Longitudinal Business Frame (LBF).<sup>7</sup>

Financial data are provided at the enterprise level in the LBD, which are legal entities (e.g. companies or partnership). For statistical purposes, enterprises may be divided into distinct economic activities, referred to as Kind of Activity Units (KAUs). Each activity is then associated with one or more geographic units (GEO), which identify the geographical locations (at a meshblock level) of real-world operating units (i.e. farm, factory, office, etc.). Figure 1 (left panel) summarises the different structures firms in the database may have.

Farm inputs are sourced from the Agricultural Production Survey/Census (APS/APC). These are collected as part of an ongoing programme of agricultural production statistics conducted in partnership between Statistics New Zealand and the Ministry for Primary Industries. During (census) survey years, the questionnaire is posted in July for (all) selected businesses that were identified in the LBF as being engaged in agricultural production activity (i.e. livestock, horticultural, forestry, etc.), or owning land that was intended for agricultural activity. We use data from the APS for the periods between 2003 – 2006 and 2008 – 2011; and data from the APC for the 2002, 2007 and 2012 years.

Information from the APS and APC is collected at the sub-KAU level (farm or group of farms) with a distinct geographical location (GEO), while the financial data are measured at the enterprise (firm) level. Single-farm firms account for 80% of our sample. However, since we cannot allocate financial data to geographical location for the remaining units, we analyse the data at the enterprise level, aggregating the KAU/GEO level agricultural production data.

Weather-related variables are collected from the National Institute of Water and Atmospheric Research (NIWA).<sup>8</sup> The data are supplied as monthly gridpoint values (5km resolution) for rainfall, soil moisture deficit and temperature, and are linked to the LBD by taking the nearest grid location

---

<sup>6</sup> See Fabling (2009) for an introduction to the LBD. In addition, we use the methodology suggested by Fabling (2011) for repairing broken firm identifiers.

<sup>7</sup> For more information about the LBF, see Seyb (2003).

<sup>8</sup> NIWA makes no representations or warranties regarding the accuracy or completeness of the climate data, the use to which the data may be put, or the results which may be obtained from using the data, and NIWA accepts no liability for any loss or damage (whether direct or indirect) incurred by any person through the use of or reliance on the data.

for each meshblock centroid (farm location is identified at the meshblock level) and assigning the environmental characteristics at that grid point to the farm.<sup>9</sup> The data is aggregated up to the firm and year levels by averaging the monthly data for each meshblock, and then taking the unweighted mean or sum (depending on the variable of interest) of all the relevant meshblocks.

Land quality variables are sourced from Landcare Research New Zealand’s Land Resource Information system.<sup>10</sup> These are linked to each enterprise by matching the meshblock each enterprise occupies with its respective quality measure. This is achieved by creating a number of binary variables indicating whether each firm had at any time point at least one meshblock under each Land-Use-Capability (LUC) and slope category.

Finally, allocation to regional councils is based on the meshblock occupied by each firm, and recorded by a set of regional council binary variables.<sup>11</sup> The process of aggregating farm level data to the firm level is summarised graphically in the right panel of Figure 1.

**Figure 1 - Schematic of firm structures (left) and geospatial linking (right)**

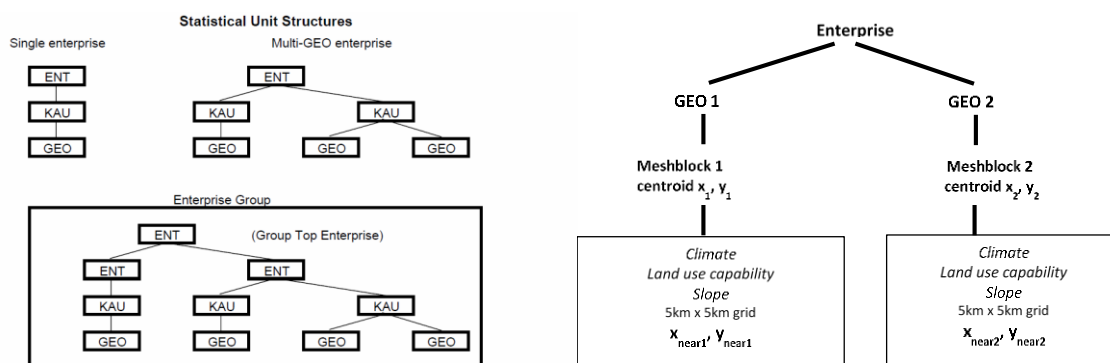

Source: Statistics New Zealand (2015)

### 3.2. Sample population

Our sample is comprised of firms (i.e. enterprises) coded to the agricultural industry of interest in the productivity dataset.<sup>12</sup> In addition, firms must also be coded to the same industry group in the APC,<sup>13</sup>

<sup>9</sup> Some meshblocks cover a wide area, which introduces measurement error if there is significant variation in weather or environmental characteristics within a meshblock.

<sup>10</sup> For more information about these measures, see Lynn et al. (2009).

<sup>11</sup> This results in some firms occupying meshblocks in more than one regional council. These account for about 2.5% of our sample.

<sup>12</sup> The productivity dataset includes the production function variables and industry coding based on predominant (employment-weighted) firm-level industry between 2000 and 2012. Dairy (sheep/beef) firms are represented by the A016000 (A014100-A014400) ANZSIC06 classifications. For information about the ANZSIC06 code and its implementation in the agricultural industry in New Zealand, see Statistics New Zealand (2008).

<sup>13</sup> Industry coding is done by Statistics New Zealand based on the returned survey information that year.

have employment in a geographical unit that is classified to the agricultural industry of interest, and have a positive amount of productive land.

To ensure that the farms considered are predominantly operating in the industry of interest, we introduce additional restrictions. Firstly, dairy or sheep/beef must be their primary activity, predominating over any secondary economic activities. Secondly, firms must not have more deer, horses, pigs or hens than cows if they are labelled dairy firms; or no more dairy cows, horses, pigs, or hens than sheep/beef cattle/deer if they are labelled as sheep/beef firms.<sup>14</sup> Finally, firms must not have more land devoted to forestry than to their main activity.

We label dairy firms as those with a positive amount of (owned) dairy cows, and at least 80% of (weighted) stock being dairy cattle and rising. Sheep/beef firms are labelled as any firm with a positive amount of sheep/beef cattle and/or deer, with at least 80% of (weighted) stock being sheep, beef and deer.<sup>15</sup> After these restrictions, our sample includes 83,964 observations from 31,920 firms.<sup>16</sup>

Assessment of the representativeness of our sample can be found in Appendix 1.

### **3.3. Variables**

The variables selected were chosen based on their availability in each year over the entire period (e.g. the question appeared in all APS/APC questionnaires between 2002 and 2012), having a sufficient number of respondents to each, their relevance to variables used in the literature, and following additional discussions with staff from the Ministry of Primary Industries (MPI) and Ministry for the Environment (MfE).

Output is measured as gross output, deflated by the industry-specific (output) Producer Price Index (PPI). Our main inputs are capital, labour, intermediate expenditure and productive land. Labour and productive land are not financial variables. Labour measures the annual sum of total rolling mean monthly employment plus a headcount measure of working proprietors, while productive land is the sum (in hectares) of various land types which are relevant to the production of dairy and sheep/beef agricultural output. One of the major fixed assets comprising the capital variable is the cost of land and buildings. Since the capital variable captures price, which reflects quality and volume, the estimated coefficient on the land variable is expected to be downward-biased, since it also measures the quantity of the land used.

---

<sup>14</sup> For both types of firm, this comparison is based on unweighted head count, and thus is more restrictive since the density of smaller breed of stock (i.e. poultry) can be greater than the sheep/beef or dairy cattle count.

<sup>15</sup> Firms with 80% or more from one 'type' of (weighted) stock account for 93% of our initial sample. Modelling firms with more of a mixed stocks largely resulted in statistically insignificant estimates due to small sample size.

<sup>16</sup> All counts are random rounded in compliance with Statistics NZ confidentiality requirements.

Our APS/APC variables include dairy and sheep/beef stockrates (i.e. weighted animal stock per hectare of productive land),<sup>17, 18</sup> secondary production variables,<sup>19</sup> and fertilizer and effluent variables. The price of stock and cost of fertilizers are already recorded as part of the capital and intermediate expenditure variables, respectively. In addition, both of these variables are measured as ratios to productive land, which is included separately. Therefore, we expect the coefficients of these ratios to be biased, with the direction of the bias depending on the strength in the correlation this variable has with capital (or expenditure) and land.

Weather variables considered include annual days of soil moisture deficit (DSMD), rainfall (in mm), and average temperature. Unfortunately, weather information is only available until the end of 2011, thus we exclude these variables from our benchmark model.<sup>20</sup> Similarly, land quality variables (Land Use Capability (LUC) and slope gradient) are time-invariant, and thus excluded from our benchmark model since these are captured by the firm effects. However, these are examined in alternative specifications.

Finally, we account for multi-KAU firms, firms operating in multiple regions, and entering and exiting firms by including binary indicators. For a more detailed summary of the variables used, see appendix 2.

## 4. Descriptive statistics

Our sample includes 83,964 observations from 31,920 firms. 73% (70%) of the observations (firms) are from the sheep/beef industry. Focusing on census years, the proportion of sheep/beef observations fell between 2002 and 2012 (table 1), with output (as a % of total output) falling at a faster rate, resulting in dairy firms accounting for over half of the 2012 aggregate output, but for only a third of all firms.

---

<sup>17</sup> Livestock (for all animals) is reported at the 30<sup>th</sup> of June each year, whereas animals may have been bought, sold or otherwise disposed of throughout the year. As with productive assets more generally, point-in-time measurement of the stock level may under- or over-estimate the size of the average stock used to produce output during the year.

<sup>18</sup> Beyond the distinction between dairy and rising, other characteristic of the animals are ignored. In particular, all dairy cows are treated as being in milk, since this was the case for most farms. For example, at the 50<sup>th</sup> (5<sup>th</sup>) percentile of dairy farms, 100% (78%) of cows were reported to be in milk.

<sup>19</sup> We tested whether dummy indicators were required for all secondary activities, but most were engaged in by a small number of farms and were not significantly related to output.

<sup>20</sup> We prefer an additional (census) year of observations over weather information, since much the weather patterns will be captured by the fixed effects (e.g. national level droughts, time-invariant spatial differences).

**Table 1 - Output changes between industries, 2002/2007/2012**

	Output (2007 NZD \$M)			Firms			Output per firm (2007 NZD\$)	
	Dairy	Sheep/beef	Sheep/beef share	Dairy	Sheep/beef	Sheep/beef share	Dairy	Sheep/beef
2002	1,840	2,380	56%	4,842	12,075	71%	380,000	197,100
2007	1,930	2,190	53%	3,426	10,749	75%	553,340	203,740
2012	1,960	1,810	48%	3,672	7,885	68%	533,770	229,550

Notes: Industries are comprised of all firms with over 50% of the relevant (weighted) stock rate (compared with the 80% threshold applied for the regression analysis) in order to get more complete information regarding changes occurring in the industry. Firm counts are based on counts that have been randomly rounded to base 3 for confidentiality reasons.

On average, each sheep/beef firm appears 2.8 times in the sample, slightly higher than for dairy firms (2.3). Figure 2 plots the proportion of firms by the number of times they appear in the sample. In the dairy industry, firms appearing once account for 20% of the sub-sample (about 14% in sheep/beef), which effectively omits these firms from the regression analysis when we include firm fixed effects.

**Figure 2 - Distribution of firms by number of appearances in the sample**

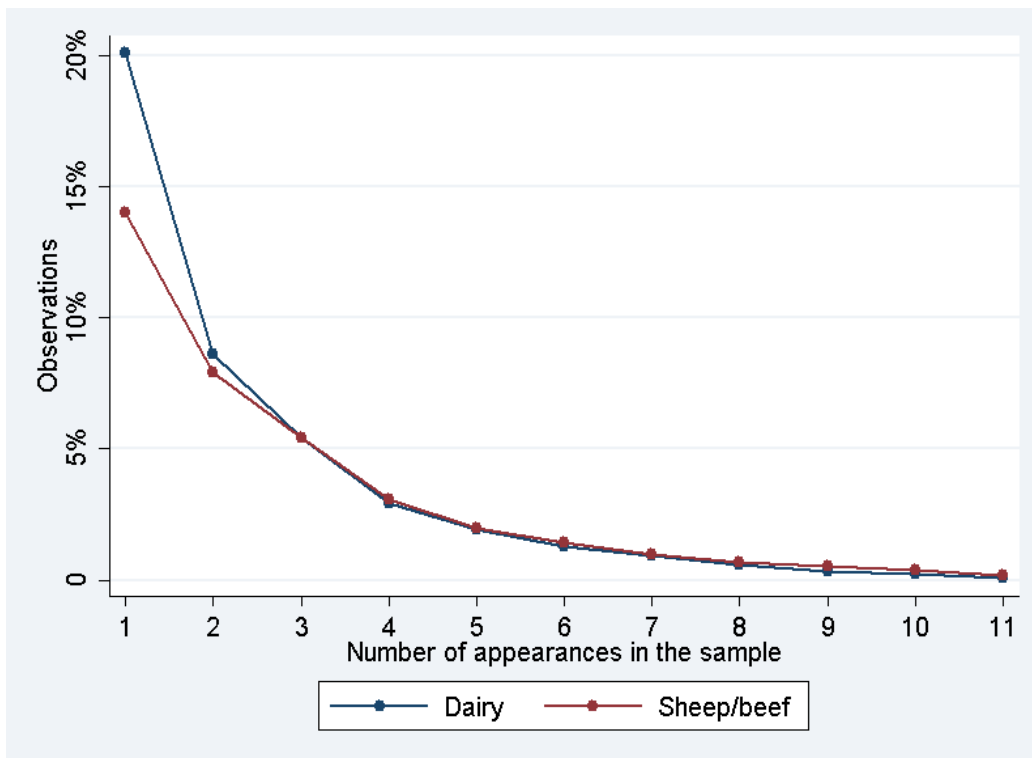

Notes: percentages are calculated from counts that have been randomly rounded to base 3 for confidentiality reasons.

Table 2 summarises the means and standard deviations for variables in each industry. On average, dairy firms produce greater output, but also utilise higher inputs. In addition, dairy firms are relatively less reliant on labour and the quantity of productive land in the production process, with output-per-hectare and the output-to-labour ratios up to three times greater than in the sheep/beef industry. On the other hand, output-to-capital and output-to-expenditure ratios were similar across industries.

**Table 2 - Descriptive statistics**

Variable	Dairy		Sheep/beef	
	Mean	<i>Standard deviation</i>	Mean	<i>Standard deviation</i>
ln(Gross output)	12.80	1.03	11.38	1.69
ln(Capital)	12.05	1.07	10.95	1.29
ln(Labour)	0.30	0.84	-0.10	0.71
ln(Intermediate expenditure)	12.26	1.12	11.13	1.46
ln(Productive Land)	6.77	1.01	6.60	1.97
Sheep-beef stock share	0.02	0.04	0.99	0.03
Milking cows share	0.94	0.17	0.79	0.38
ln(Stocking rate): Dairy	2.76	0.53	-0.02	0.33
ln(Stocking rate): Sheep-Beef	-0.26	0.83	2.20	0.65
Produce Silage-Balage	0.74	0.44	0.53	0.50
Forest Harvesting	0.01	0.08	0.01	0.11
ln(Fertilizer application rate): Lime	-0.94	0.93	-1.45	1.25
ln(Fertilizer application rate): non-Lime	-1.02	0.93	-2.02	1.25
ln(Effluent application rate)	-2.05	0.74	-1.87	1.59
Fertilizer non-application rate: Lime	0.52	0.50	0.65	0.48
Fertilizer non-application rate: Non-Lime	0.11	0.32	0.38	0.49
Effluent non-application rate	0.32	0.47	0.99	0.08
Multi-KAU firms	0.24	0.42	0.18	0.38
Multi-RC firms	0.04	0.19	0.02	0.15
Newly established firms	0.02	0.16	0.03	0.16
Exiting firms	0.07	0.25	0.08	0.27
Slope category: A-C	0.68	0.47	0.54	0.50
Land Utilisation Category (LUC): 1-3	0.54	0.50	0.39	0.49
Days of Soil Moisture Deficit	3.42	0.97	3.71	0.97

ln(Rainfall)	7.15	0.43	7.03	0.41
ln(Temperature)	2.55	0.16	2.50	0.16
Total Firms / observations	9,714 / 22,710		22,206 / 61,254	

Notes: observations are based on counts that have been randomly rounded to base 3 for confidentiality reasons. Application rates for fertilisers and effluent reported for the subset of firms that applied any positive amount.

Figure 3 suggests that, in many instances, the lower mean values found for sheep/beef firms are driven (at least to some extent) by a greater variation across firms, with a high proportion operating at a below-average level in the industry (compared with dairy which seems to be more homogenous in activity). In addition, the figure shows that, with the exception of labour, the distribution of the other production function variables is fairly bell-shaped in distribution. Labour is clustered around a small set of specific values (e.g. a single working proprietor), with the most firms operating with no more than seven workers.

**Figure 3 - Kernel density, Production function inputs and output**

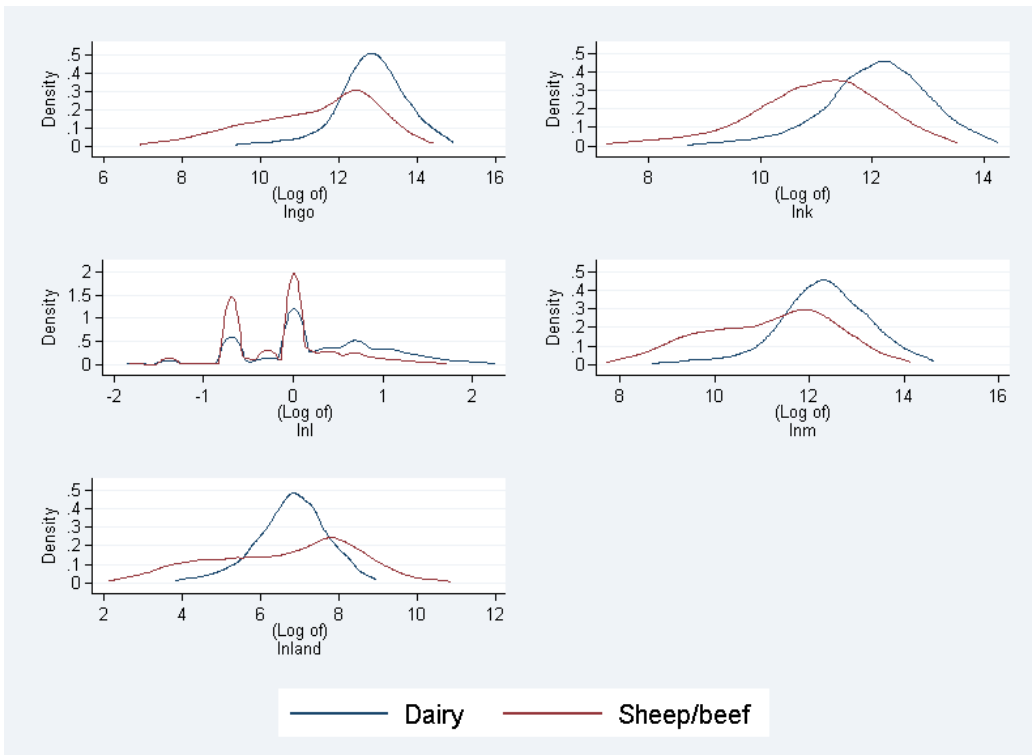

Notes: Plots exclude observations from the top and bottom 1% for confidentiality reasons. Density is of logged values.

With respect to differences in agricultural inputs, table 3 shows that dairy firms have greater stockrates, and are more likely to produce silage-balage and to operate on better quality land (i.e.

Slope and LUC). This last statistic may relate to the greater output-to-land ratio; that is, dairy firms are able to produce greater output from each hectare of land utilised, since that land is, on average, of better quality. These differences are controlled for in our subsequent regressions.

Other differences include sheep/beef firms being more likely to apply non-lime based fertilisers, and less likely to use lime-based fertilisers and effluent. Multi-KAU firms account for about 24% of dairy firms and 18% of sheep/beef firms, with a smaller proportion of Multi-RC firms (4% of dairy firms and 2% of sheep/beef firms). Firms in their first year of operation account for about 2% of dairy firms, and 3% of sheep/beef firms, while exiting (in the following year) firms account for 7% and 8% respectively. Despite the differences in land quality and slope variables, the table does not suggest any great differences in average weather conditions between the industries (dairy firms tend to operate in areas with a slightly greater rainfall, and slightly lower DSMD). Finally, the great majority of dairy cows have been reported to produce milk, and almost no firms reported any forestry activity (due, in part, to our sample selection criteria). For additional descriptive analysis, see appendix 3.

## **5. Results**

### **5.1. Results by industry**

#### **5.1.1. Dairy**

Regression results for the dairy industry are summarised in table 6 in appendix 4. Column 1 estimates the data using a pooled OLS, finding that the majority (89%) of the variation in output across firms can be explained by variations in capital, labour, expenditure and land. Introducing firm and year effects (second column) increases the adjusted  $R^2$  to 96%. Introducing these effects also influences the value of the production function coefficients, implying that the nature and strength of the relationship between inputs and output is related to the time-invariant characteristics of the firm, and to industry-wide changes in productivity.

Examining the production function coefficients suggests that capital and land have a complementary relationship (though the coefficient is statistically insignificant), while expenditure is a substitute to both capital and land. On the other hand, all of the interactions with labour are very small and statistically insignificant. This may suggest constant elasticity of substitution between labour and all other inputs, or could simply reflect the low variation of labour input in the data. At the mean, a 10% increase in capital, labour, expenditure and land are associated with an output increase of approximately 1.8%, 1.3%, 5.1% and 1%, respectively.

Introducing augmented controls (third to seventh column) does not affect the main production function coefficients, suggesting a degree of independence between these controls and the production function coefficients. Furthermore, the contribution of these controls to the overall explanatory power of the model is limited. However, a key benefit of including these additional variables is the ability to quantify how differences in farm practices relate to changes in output.

In dairy firms, more intensive land use (higher dairy stockrates) is associated with higher output as is the application of some fertilisers. On the other hand, there is no evidence that non-dairy activity (e.g. forestry work) has any impact on output. Increasing dairy stockrates (i.e. dairy units per hectare of productive land) by 10% was associated with a 0.5% increase in output. At the mean, this translates to an additional 1.5 units per hectare and an output increase of about \$1,800. With respect to fertilisers, the (mean) output of firms applying non-lime fertilisers and effluent (to any extent) was 3% and 6.2 – 6.5% (respectively) greater than for firms who did not. A 10% increase in effluent application rates (i.e. tonnage of effluent per hectare of productive land) is associated with a 0.14% increase in output, or at the mean, an increase of \$500 in output for every additional 13 kg of effluent applied per hectare.

Compared with continuing firms, both firms in their first and final year of dairy operation recorded lower output on average (about 7% and 5% respectively). On the other hand, no differences in output were recorded for multi-KAU and multi-region firms. With respect to differences in weather and land conditions, a 10% increase in the number of days of soil moisture deficit was associated with an output drop of 0.3% (column 7), noting that constant differences in rainfall across farms are controlled for by firm effects. Replacing firm fixed effects with regional council dummies, we estimate the mean output of firms with at least one meshblock with slope A-C categories (columns 8 and 9) was greater by 1.4%.

### **5.1.2. Sheep/beef**

Results for the sheep/beef industry are summarised in table 7 in appendix 4. As found for dairy firms, most of the variation in output is explained by the production function inputs and fixed effects (adjusted  $R^2$  of 95%). Further, including the augmented controls offers only a marginal improvement to the models' overall explanatory power, but includes many significant agricultural inputs.

The two industries are also similar in the significance and direction of the production function coefficients (and their interaction with one another). In terms of magnitude, at the means, a 10% increase in capital, labour, and land had a lower association (than found in dairy) with output increasing by 1.3%, 0.6%, and 0.8% respectively. However, the expenditure elasticity was substantially larger for sheep/beef, with a 7.3% increase in output when this input increased by 10%.

As with dairy, sheep/beef firms producing more intensively recorded higher output, with a 10% increase in sheep/beef stockrates associated with a 1.2% increase in output. At the mean, this is equivalent to an additional 0.9 (weighted) sheep/beef units per hectare of productive land and an increase in output of about \$1,000.<sup>21</sup> Sheep/beef firms also appear to benefit from secondary activities. For example, firms with any positive amount of (weighted) dairy rising and cattle has higher average output by 3.2% and 4.5%, respectively, while firms harvesting (any positive level of) forest had higher mean output by 6% (equivalent to around \$5,200).

Firms applying lime and non-lime fertilisers (to any degree of intensity), recorded a lower mean output by about 2 percentage points compared to firms that did not. One possible hypothesis for this counterintuitive association is that these fertilizers are applied as a response to adverse time-variant/farm-specific shocks.<sup>22</sup>

The relationship between firm characteristics and output was very similar across industries. One main difference is that the performance of sheep/beef firms in their first year is less favourable than that of dairy firms in their first year. While firms in both industries record output comparatively lower than continuing firms, the difference in their mean output was much greater for newly established sheep/beef firms than for dairy (12% compared with 7%).

The DSMD and rainfall weather variables (column 7) are significant and negative. While this result is expected for the DSMD, it is counterintuitive with respect to annual rainfall. One possible explanation for this result is the high correlation between weather variables. Finally, more favourable land characteristic variables were not significantly associated with output (column 9), suggesting that the quality of land is not as critical in the sheep/beef industry as it is for the dairy industry.

## 5.2. Productivity

### 5.2.1. Industry level trends<sup>23</sup>

Figure 4 plots estimated annual changes in MFP for each industry between 2002 and 2012. The annual changes in MFP are relative to the 2002 MFP levels in each industry, normalised to zero. To account for the possibility that changes in MFP are influenced by sample selection issues (especially in

---

<sup>21</sup> This rate is about 0.7 percentage points greater than in dairy, perhaps due to the fact that the mean stockrates of dairy cattle are about 1.5 times that of sheep/beef.

<sup>22</sup> For example, columns 8 and 9 in table 7 show that within a region, firms applying (any positive amount of) non-lime fertilizer and effluent record a greater mean output than firms who don't.

<sup>23</sup> Note that our MFP measures are not comparable to the official statistics. We measure the (unweighted) average level of productivity across firms in our sample in each industry-year, whereas official statistics measure the aggregate productivity of the entire industry. For more information on how the official productivity statistics are measured, see Statistics New Zealand (2014).

non-census years), we also estimate our model including all available observations from the firm productivity dataset (i.e. all available years of data for firms that appeared in our sample). This sample includes 146,501 sheep/beef (53,553 dairy) firms.<sup>24</sup>

**Figure 4 – Annual MFP changes by industry, 2002 – 2012**

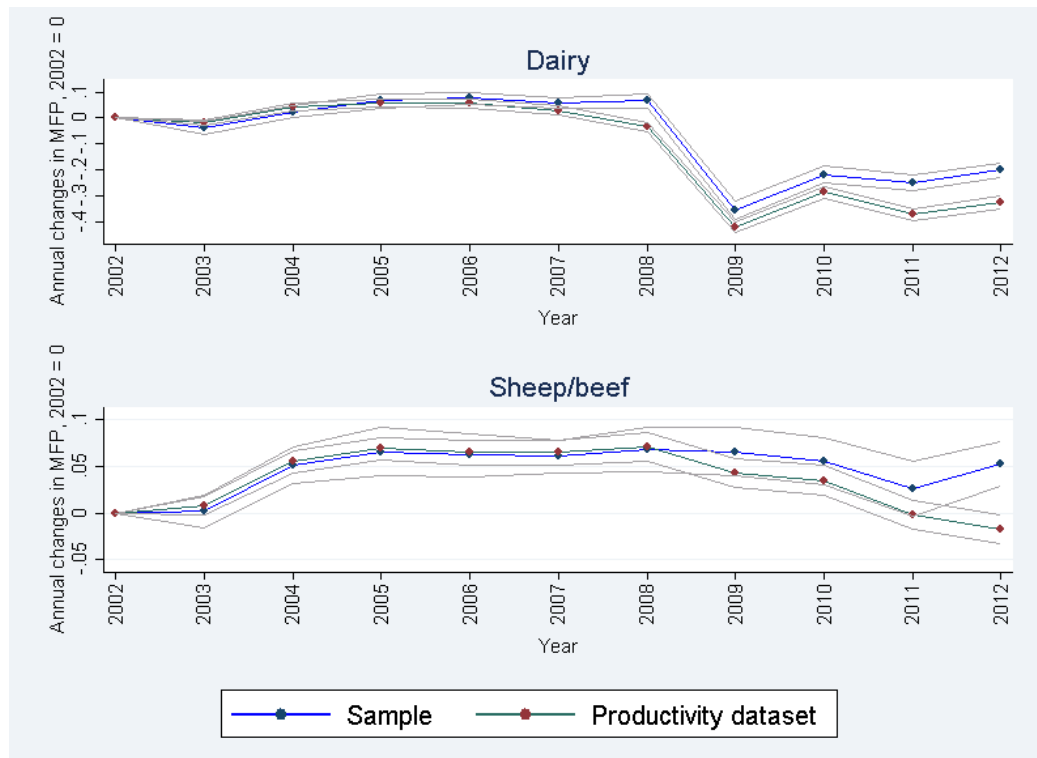

Notes: MFP is derived from the period fixed effects using the two-way industry level models. The MFP level is relative to the 2002 level in each industry, which is set to 0. 95% confidence intervals are in grey.

For dairy, average MFP increased between 2002 and 2008 (an annual change of about 1.3%). However, the industry recorded a significant drop in MFP levels in 2009 (a 35% fall), still lagging its 2002 MFP levels in 2012, despite some recovery after 2009. Overall, a similar MFP trend is observed from the productivity dataset based model. One main difference is that MFP starts declining one year earlier, and is comparatively lower than the measure of our restricted sample between 2009 and 2012. In the sheep/beef industry, MFP increased in most years, following a more stable trend than found for dairy. A drop in MFP was recorded in 2010, though it remained above its 2002 levels. However,

<sup>24</sup> We exclude observations when firms' ANZSIC06 code does not match the stock-based industry group. This resulted in removing 2% of the observations. In addition, the model used is a two-way fixed effect second order Translog, allowing for the capital, labour, and intermediate expenditure variables. Therefore, some differences in the results may be driven by differences in model specification.

as in dairy, the productivity dataset portrays a similar but less favourable trend with MFP below its 2002 levels since 2011.

### 5.2.2. Time-invariant differences in productivity between regional councils

Long-term/permanent differences in MFP across regions are derived from the regional regressions (column 8 of tables 6 & 7), using the regional council effects and capturing the overall association between the time-invariant (or very slow to adjust) factors and output. Figure 5 graphs these differences, setting the MFP level of each region relative to that of the Northland region, which is normalised to zero. Productivity is measured controlling for input quality differences (as far as these are captured by factor prices), which represents a significant deviation from raw comparisons of output-per-hectare across locations (some comparisons of this latter sort are presented in Appendix 3).

**Figure 5 - Long-term/permanent regional differences in MFP**



Notes: MFP is derived from the regional council effects using the two-way regional models. The MFP level is relative to that of the Northland region, which is set to 0. Results are sorted from the lowest to highest MFP values.

In the dairy industry, the greatest productivity levels were found in the Taranaki, Otago and Hawke’s Bay regions (about 7% greater than in Northland). These were followed by the Manawatu-Wanganui, Southland, and Canterbury regions (5-6%). Gisborne recorded the lowest productivity level, at almost

20% below that of Northland. In the sheep/beef industry, Southland recorded the greatest MFP with at almost 20% above Northland. Other productive regions include Nelson (16%), Gisborne (15%), Hawke's Bay (14%) and Manawatu-Wanganui (10%). On the other hand, most other South Island regions recorded a lower MFP relative to Northland (about 2-3%).

Overall, the figures suggest large variations of MFP across regions, although we are unable to assess the extent to which these arise from differences between the regions themselves (e.g. access to port, preferable climate, etc.), or differences between the firms in each region (e.g. management skills, access to capital, etc.). Annual changes in regional MFP trends for selected regions (based on estimates from column 9 of tables 6 & 7) are available in appendix 5.

## 6. Robustness tests

We now perform a number of procedures to test the robustness of our model. We first examine the validity of our assumption regarding the structure of the firm productivity term. Next we evaluate the extent to which the models are able to account for heterogeneity in the dairy and sheep/beef industries, focussing on two aspects of heterogeneity - employment composition, and farm size.

### 6.1.1. Structure of firm productivity term

In tables 4 and 5, the rightmost (i.e. ninth) columns include two-way regional models with interaction between the two effects. These capture temporal changes in MFP, unique to each regional council (e.g. drought in region  $J$ , at year  $T$ ). If these trends have a significant influence over the productivity of the various inputs, then their coefficients in the two-way regional models (column 8 in tables 4 and 5) will be biased, as they also capture unobserved regional productivity shocks. Thus, including these interactions would 'correct' the bias, altering the values of the affected coefficients. However, little to no difference was found when comparing the coefficients across specifications in each industry. That is, although the interactions do improve the model by explaining additional variability caused by sub-national shocks, overall, the results suggest that the associations found in the two-way models was not biased due to unobserved regional trends.<sup>25</sup> Therefore, we do not find evidence to refute our central assumption regarding the firm productivity term – i.e. that it is time and firm separable.<sup>26</sup>

---

<sup>25</sup> The share of such firms is even greater when examining official statistics. For example, the Business Demography Statistics suggest that in 2014, about two-thirds and half of all sheep/beef and dairy enterprises were defined as zero employee firms, respectively.

<sup>26</sup> However, this does not imply that our assumption is correct either, e.g. whether there is unobserved correlation at a different geographical level which is not captured by the regional council dummies (e.g. territorial authority, local labour market, etc.), or by non-geographical unobserved variables.

### 6.1.2. Employment composition

We now examine whether working proprietor-only firms (WP-only firms) have different technology than that of the industry overall. WP-only firms operate with one or more owner and do not have any employees. These firms account for a third of all dairy firms and over half of all sheep/beef firms in our sample. Their small size makes them more susceptible to measurement errors (Fabling and Sanderson, 2014).

We estimate our benchmark models additionally including a WP-only dummy variable (to measure differences in mean output), which is also interacted with all inputs (to capture any differences in the association between inputs and output for these firms). The results are summarised in table 8 in appendix 4. In both industries, the WP-only variable and most interactions of this variable with other variables are not significantly different from zero (at the 10% level).<sup>27</sup> In addition, comparing the predicted output using the benchmark and WP-specific models (Figure 6) shows almost identical values (greatest difference found for dairy firms with logged output ranges around 10 and 11). Therefore, although there are some differences in technology, these are few and have a limited impact on the overall predictions of the models.

---

<sup>27</sup> To recover the coefficient of interest for a WP-only firm from the estimates reported in tables 4 & 5, it is necessary to sum the relevant employing firm coefficient with the WP-only interaction term. The insignificance of the interaction term indicates that the summed WP-only coefficient is not significantly different from the employing firm coefficient.

**Figure 6 – Distribution of predicted gross output across models**

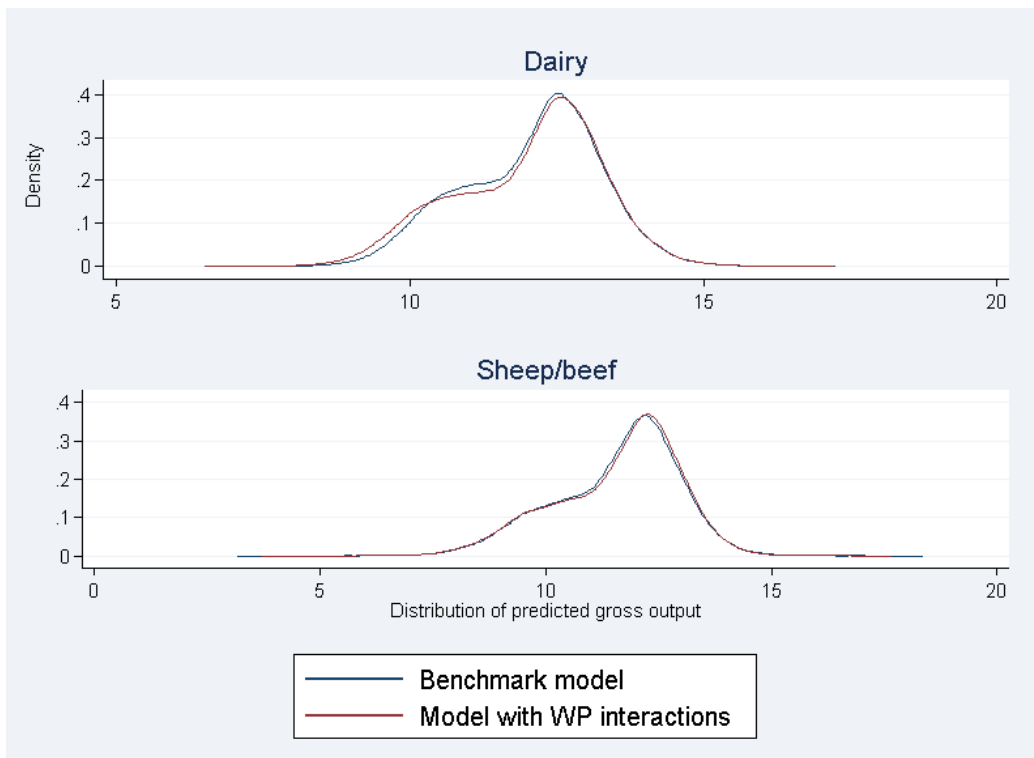

Notes: figure excludes top and bottom 1% of observations for confidentiality reasons.

### 6.1.3. Output elasticities for firm with different land size

We now test whether output elasticities differ for firms with different land sizes. To test this, we take all firms from each industry and group them according to the productive land quartile. We then estimate our benchmark model, calculating capital, labour, expenditure and land elasticities for each sub-group. Due to the structure of the Translog function, variation in elasticities could result from differences in technologies (i.e. coefficients) and/or input levels. Here, we are interested in whether any variations are driven by differences in technology, and thus hold the input levels fixed (to the mean input levels in each industry) when comparing the elasticities.

Table 3 summarises the elasticities derived from each regression, presented as the associated output increase following a 10% increase in input (holding input fixed at the industry mean level). Estimated elasticities vary substantially by sub-group. Overall, we conclude that the differences in the estimates across sub-groups are, perhaps, too large to be accurately captured by a whole-of- industry model.<sup>28</sup>

<sup>28</sup> We also compared the predicted output between the full and land quartile specific models, both when holding inputs level fixed at the industry overall mean, and when setting inputs to the mean of the sub-samples. In all cases, for each pair, the results were substantially different.

**Table 3 - Output elasticities by land quartile, by industry**

Elasticity	Dairy					Sheep/Beef				
	Full Sample	Lowest 25 <sup>th</sup>	25 <sup>th</sup> to median	Median to 75 <sup>th</sup>	75 <sup>th</sup> and over	Full Sample	Lowest 25 <sup>th</sup>	25 <sup>th</sup> to median	Median to 75 <sup>th</sup>	75 <sup>th</sup> and over
Capital	1.8*** [0.2]	0.5 [1.0]	1.3*** [0.3]	1.0** [0.5]	1.1** [0.5]	1.3*** [0.1]	2.5** [1.2]	1.2*** [0.3]	0.5** [0.2]	0.6** [0.3]
Labour	1.3*** [0.2]	1.5 [1.1]	1.2*** [0.3]	1.6*** [0.5]	1.8*** [0.2]	0.6*** [0.1]	2.0 [1.7]	0.9** [0.4]	0.7** [0.3]	1.2*** [0.3]
Expenditure	5.1*** [0.2]	4.9*** [1.1]	4.8*** [0.3]	5.7*** [0.5]	4.5*** [0.4]	7.3*** [0.1]	8.2*** [1.1]	7.4*** [0.3]	6.4*** [0.3]	5.7*** [0.3]
Land	1.0*** [0.4]	6.2 [4.1]	3.6** [1.6]	-1.6 [3.4]	1.1 [0.7]	0.8*** [0.1]	0.4 [2.3]	0.5 [0.9]	0.7 [1.4]	1.3** [0.6]

Notes: Input levels are held fixed at the mean input level throughout the entire industry. Robust standard errors in brackets; \*\*\* p<0.01, \*\* p<0.05, \* p<0.1. Elasticities are presented as the associated change in output following a 10% increase in input from the industry mean.

## 7. Conclusions

We have explored what linking different sources of firm level data reveals about the magnitude and nature of the relationship between financial, agricultural, geographical and weather inputs and output in the New Zealand dairy and sheep/beef industries. By linking these data we were able to quantify relationships and produce estimates for firm-level multifactor productivity (MFP), as well as estimate average industry and regional council MFP.

We estimated production functions using augmented two-way fixed effect second order Translog models, finding most output variation to be explained by our models. We find much difference between the industries in terms of both the magnitude of estimated elasticities and the actual inputs that were found to be associated with output. For example, dairy firms (which tend to produce greater output) had a stronger association between capital, labour and land inputs and output, and seemed more focussed on producing their primary output. On the other hand, sheep/beef firms recorded a stronger association between intermediate expenditure and output, and also benefited from certain non-sheep/beef activity (e.g. dairy, forestry). In addition, our results suggest that the output of dairy firms was related to the quality of the land used, while this was not the case for sheep/beef firms.

Our estimates show that between 2002 and 2008, the MFP level in the dairy industry increased more rapidly than that of sheep/beef. This has since reversed, following a sharp drop in dairy's MFP level in 2009. Although some improvement has since been recorded, average MFP levels in the dairy industry remain lower than in the past.

Finally, we found significant heterogeneity in technology across firms with different land size, too large to be accurately captured by models that pool small and large firms together with common coefficients. Therefore, while we believe that our models approximated the industry level production functions fairly accurately, future studies should consider applying more sub-group-specific models, that explicitly address the within industry heterogeneity present in the data.

## 8. References

- Ackerberg, Daniel A, Kevin Caves, and Garth Frazer. 2006. "Structural Identification of Production Functions." *Mimeo, UCLA* December 28, 2006.
- Christensen, Laurits, Dale W Jorgenson, and Lawrence J Lau. 1973. "Transcendental Logarithmic Production Frontiers." *Review of Economics and Statistics* 55: 29–45.
- Fabling, Richard. 2009. "A Rough Guide to New Zealand's Longitudinal Business Database." Global COE Hi-Stat Discussion Paper Series gd09-103. Institute of Economic Research, Hitotsubashi University.
- . 2011. "Keeping It Together: Tracking Firms on New Zealand's Longitudinal Business Database." Motu Working Paper 11-01. Motu Working Papers. Wellington: Motu Economic and Public Policy Research.
- Fabling, Richard, and David Christopher Mare,. 2015. "Production Function Estimation Using New Zealand's Longitudinal Business Database." *Motu Working Paper* (forthcoming).
- Fabling, Richard, and Lynda Sanderson. 2014. "Productivity Distributions in New Zealand: The Dangers of International Comparisons."
- Grimes, Arthur, and Sean Hyland. 2013. "Passing the Buck: Impacts of Commodity Price Shocks on Local Outcomes." Motu Working Paper 13-10. Wellington: Motu Economic and Public Policy Research.
- Levinsohn, James, and Amil Petrin. 2003. "Estimating Production Functions Using Inputs to Control for Unobservables." *Review of Economic Studies* 70 (2): 317–41.
- Lynn, Ian, Andrew Manderson, Mike Page, Garth Harmsworth, Garth Eyles, Grant Douglas, Alec Mackay, and Peter Newsome. 2009. *Land Use Capability Survey Handbook*. Vol. 3rd. AgResearch Ltd, Hamilton; Landcare Research, Lincoln; Institute of Geological and Nuclear Sciences, Lower Hutt.
- Olley, G.Steven, and Ariel Pakes. 1996. "The Dynamics of Productivity in the Telecommunications Equipment Industry." *Econometrica* 64 (6): 1263–97.

Seyb, Allyson. 2003. "The Longitudinal Business Frame." Wellington, New Zealand: Statistics New Zealand.

Statistics New Zealand. 2008. "Farm Types Used in Agricultural Production Statistics: A Comparison between ANZSIC96 and ANZSIC06 Classifications." Wellington, New Zealand.

———. 2011. "Gross Domestic Product: March 2011 Quarter."

———. 2012. "What New Zealand Actually Does for a Living: From Manufacturing to a Services-Oriented Economy."

[http://www.stats.govt.nz/browse\\_for\\_stats/economic\\_indicators/NationalAccounts/Contribution-to-gdp.aspx](http://www.stats.govt.nz/browse_for_stats/economic_indicators/NationalAccounts/Contribution-to-gdp.aspx).

———. 2014a. "Global New Zealand – International Trade, Investment, and Travel Profile: Year Ended December 2014."

———. 2014b. "Productivity Statistics: Sources and Methods (10th Edition)."

———. 2015. "Geographic Definitions." <http://www.stats.govt.nz/Census/2013-census/info-about-2013-census-data/2013-census-definitions-forms/definitions/geographic.aspx>.

Van Beveren, Ilke. 2012. "Total Factor Productivity Estimation: A Practical Review." *Journal of Economic Surveys* 26 (1): 98–128. doi:10.1111/j.1467-6419.2010.00631.x.

Wooldridge, Jeffrey M. 2009. "On Estimating Firm-Level Production Functions Using Proxy Variables to Control for Unobservables." *Economics Letters* 104 (3): 112–14. doi:10.1016/j.econlet.2009.04.026.

## 9. Appendix

### 9.1. Appendix 1 – Representativeness of the sample<sup>29</sup>

#### 9.1.1. Sample construction

We need to ensure that our sample is sufficiently representative of the total in-scope agricultural population. To address this, we apply each of the first three population criteria described in the main text to the total possible firm population to show the impact each has on firm counts. Table 4 summarises the effect on the size of our entire sample (including mixed firms) under the initial three steps when creating our sample population, while figure 7 presents a schematic to aid interpretation.

**Figure 7 - Graphical representation of the sample and sources**

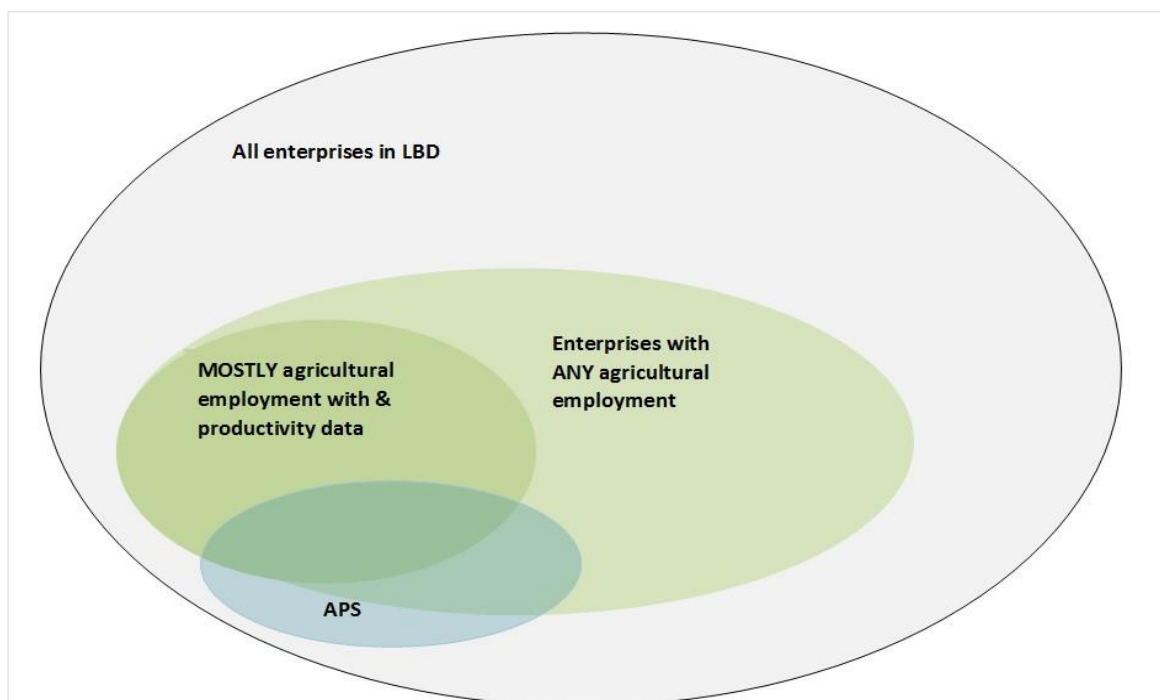

The first column of table 4 shows the number of observations in the LBD of firms with any employment classified in the relevant agricultural industries (palest green in figure 7). This includes both the firms of interest and those which own a farm for purposes which are not predominantly agricultural (e.g. education). We restrict the LBD sample to include only firms with some productivity data (i.e. a usable IR10 form) and with the bulk of its employment classified as

---

<sup>29</sup> Note that the sample treated here includes all firms with at least 50% of one type of (weighted) stock group, rather than restricting to firms with 80% or more.

agricultural in the relevant industries, reducing the sample by 42% (second column in Table 4, and darkest green in figure 7).

**Table 4 - Overall firm count in sample using different defining criteria**

Source	LBD IR10 data		APS/APC		Sample
Dataset	All agricultural firms	All agricultural with firms with productivity data	All firms provided usable response	All firms with any agricultural employment	Merging (2) and (4)
June Year	(1)	(2)	(3)	(4)	(5)
2002	53,877	32,805	49,968	28,686	18,975
2003	53,118	32,235	18,921	10,431	7,191
2004	51,345	30,930	17,337	9,345	6,900
2005	50,517	29,511	10,683	5,706	4,602
2006	51,009	27,885	17,958	8,988	6,519
2007	50,328	27,789	46,446	24,054	15,927
2008	48,006	27,723	20,940	10,638	6,948
2009	45,777	27,033	11,640	5,808	4,149
2010	44,760	26,973	17,445	8,934	6,171
2011	43,911	25,839	12,369	6,189	4,530
2012	43,920	25,005	41,904	20,898	12,648
Total	536,568	313,731	265,611	139,680	94,560
Census year	148,122	85,596	138,318	73,641	47,547
Share of column to left		58%		53%	68%
Share of column 1					18%
Share of column 2					30%
Share of column 3					36%
As above but only Census years					
Share of column to left		58%		53%	68%
Share of column 1					32%
Share of column 2					56%
Share of column 3					34%

Notes: observations are based on counts that have been randomly rounded to base 3 for confidentiality reasons.

The third and fourth columns include observations from the APS and APC. Column 3 refers to all farms that are included in the APS/APC and have provided a usable form (blue shade in figure 7). The column shows a greater number of farms in the three census years (as expected) and includes 265,611 observations. The fourth column includes only firms that have some in-scope agricultural employment (light blue-green shading in figure 7), reducing the number of observations by 47%. Finally, merging (by enterprise identifier and year) the observations from columns (2) and (4) creates the basis of our sample population. That is, firms in this sample include all those which have activity

in the relevant industry, have submitted usable IR10 forms, and received and returned a usable response to the agricultural survey or census. This includes 94,560 observations. Applying the additional restrictions on our usable sample (i.e. column 5) reduces our population by an additional five percentage points, resulting in 90,033 observations from 34,326 firms.

Considering all years, 30% of all agricultural firms with productivity data and in-scope employment have a usable APS/APC response. While the share of total population is relatively low if all years are included, there are still over 12,000 firms in each census year and over 4,500 firms in each survey year. Considering the census years only, 53% of total population is in our usable sample. This share is somewhat lower than expected for a census. We examined the reasons for this: 20% of farms that we thought might get a census form were not sent one; of this group (13%) were considered to be active on the Business Frame at the time the survey was sent out and should, perhaps, have received the form; based on the information held in the longitudinal business frame, 7% were inactive (farms may have changed ownership or ceased farming) and so should not have received forms; about 10% of firms did not respond; and 3% responded but were subsequently deemed to be out of scope. Finally, approximately 68% of firms that provided a usable APS/APC response were in our usable sample (column 5).

On the other hand, some firms will appear in the APS/APC but will not be included in the productivity dataset. Part of the reason for that is due to the ownership of some farms being in the hands of trusts, meaning that they do not satisfy the private-for-profit productivity population criteria. A back-of-the-envelope calculation suggests that 9.5% (7.8%) of dairy (sheep-beef) farms in the APS/APC are directly owned by trusts – restricting to employing farms, this share drops to 5.9% (4.2%). While these numbers represent a material proportion of the lost APS/APC sample, the following subsection demonstrates that lost observations are quite similar to those included in the analysis, consistent with a view that the choice of trust-based ownership is not correlated with how farms are operated.

### 9.1.2. Comparison to sources

We now compare the differences in the characteristics of our sample population and its various sources. First, we define the three sources we will compare our sample population against:

- ***Productivity*** - all the active firms with tax data that are coded under the relevant NZSIOC industries. The data set includes 313,731 observations from 62,811 firms between 2002 and 2012 (darkest green in figure 7).

- **APS** - Due to our aggregation process (aggregating KAU to the enterprise level), we are not able to maintain the industry ANZSIC06 classification. Thus, in order to compare the samples by industry, we applied conditions (4) and (5) to this sample, which resulted in losing approximately 33% of the observations. This sample has 216,855 observations from 62,811 firms between 2002 and 2012 (the intersection between the APS bubble and the two green bubbles in Figure 7).
- **APS/Prod** – this dataset is created by merging the productivity dataset with the (pre-clean) APS dataset according to firm identifier and year. This set includes 94,560 observations from 35,316 firms (the intersection between the blue and darkest green bubbles in Figure 7).

Figure 8 plots the number of firms for the sample population and the different datasets. The differences between survey and census years (2002, 2007, and 2012) in terms of coverage can be seen for the APS/APC dataset, as well as the samples that this set was part of. In terms of firm count, the figure suggests that the lower firm count in our sample population is mainly due to the merging process, rather than the additional conditions applied, as the sample population shows an almost identical count to the APS/Prod set in terms of observation count. In addition, Table 5 examines dataset differences for a selection of variables, finding a high degree of similarity in mean value between our sample population and the APS/Prod dataset. Similar distributions are found when examining plots of variables graphically – Figure 9 presents a selection of examples. Overall, we conclude that our sample appears to be representative based on comparison tests to the larger datasets from which our linked data originates.

**Table 5 - Summary statistics for selected variables, by source**

Variable	Sample population		Productivity		APS		APS/Prod	
	Mean	<i>Std.dev</i>	Mean	<i>Std.dev</i>	Mean	<i>Std.dev</i>	Mean	<i>Std.dev</i>
Gross output	11.79	1.65	11.40	1.75			11.77	1.64
Capital	11.27	1.32	10.86	1.47			11.26	1.31
Labour	0.01	0.77	-0.08	0.73			0.01	0.76
Intermediate expenditure	11.46	1.46	11.03	1.60			11.44	1.45
Productive Land	6.67	1.75			4.32	1.83	6.65	1.74
Milking cows share	0.72	0.43			0.73	0.42	0.70	0.43
Sheep-beef stock share	0.91	0.23			0.91	0.24	0.90	0.25
Stocking rate - Dairy	0.80	1.29			0.76	1.27	0.87	1.32
Stocking rate - Sheep-Beef	1.55	1.27			1.56	1.27	1.51	1.27
Produce Silage-Balage	0.59	0.49			0.59	0.49		

Forest Harvesting	0.01	0.10	0.01	0.10		
Slope category - A-C	0.58	0.49			0.58	0.49
LUC - 1-3	0.43	0.50			0.43	0.50
Fertilizer application rate -Lime	-1.28	1.17	-1.23	1.15	-1.27	1.16
Fertilizer application rate- non-Lime	1.68	1.24	-1.61	1.22	-1.67	1.23
Effluent application rate	2.10	0.80	-2.07	0.80	-2.10	0.81
Total Firms/observations	34,236/90,033	59,079/313,731	62,811/216,855	35,316/94,560		

Notes: firm and observation totals have been randomly rounded to base 3 for confidentiality reasons.

**Figure 8 - Firm count by year and dataset, 2002-2012**

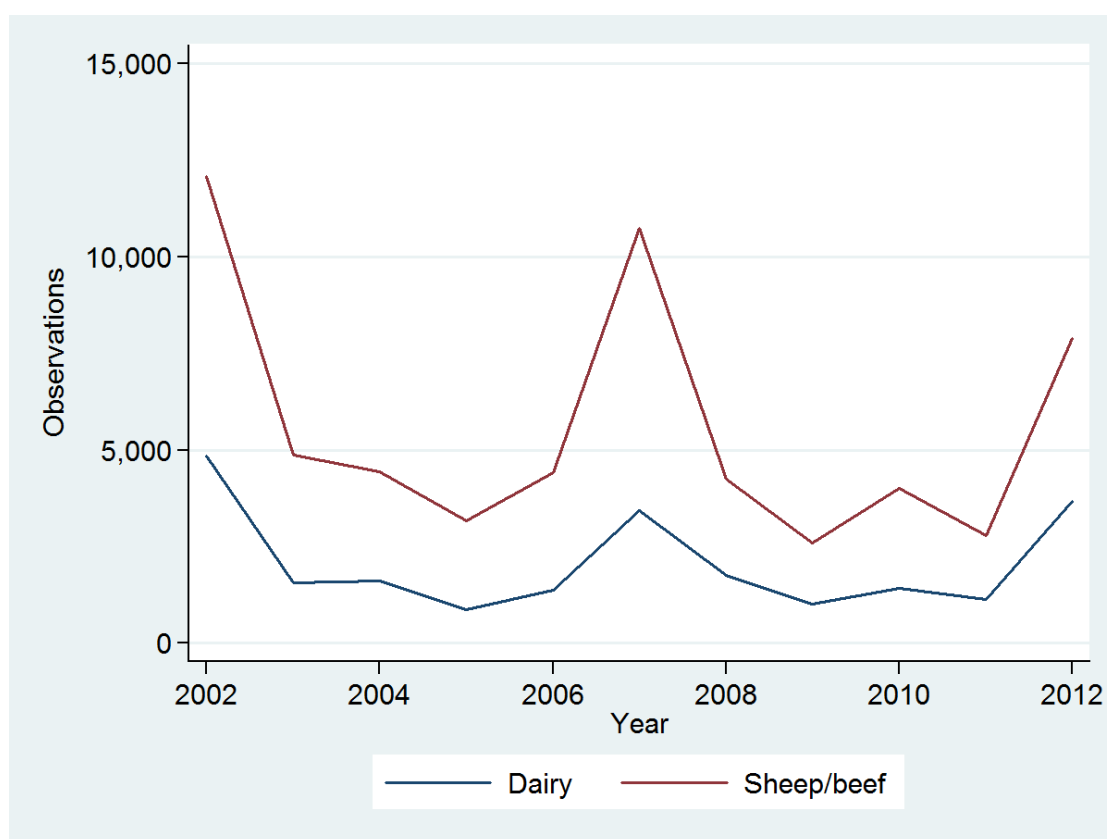

Notes: figure is based on counts that have been randomly rounded to base 3 for confidentiality reasons.

Figure 9 - Kernel density, for selection of variables by source

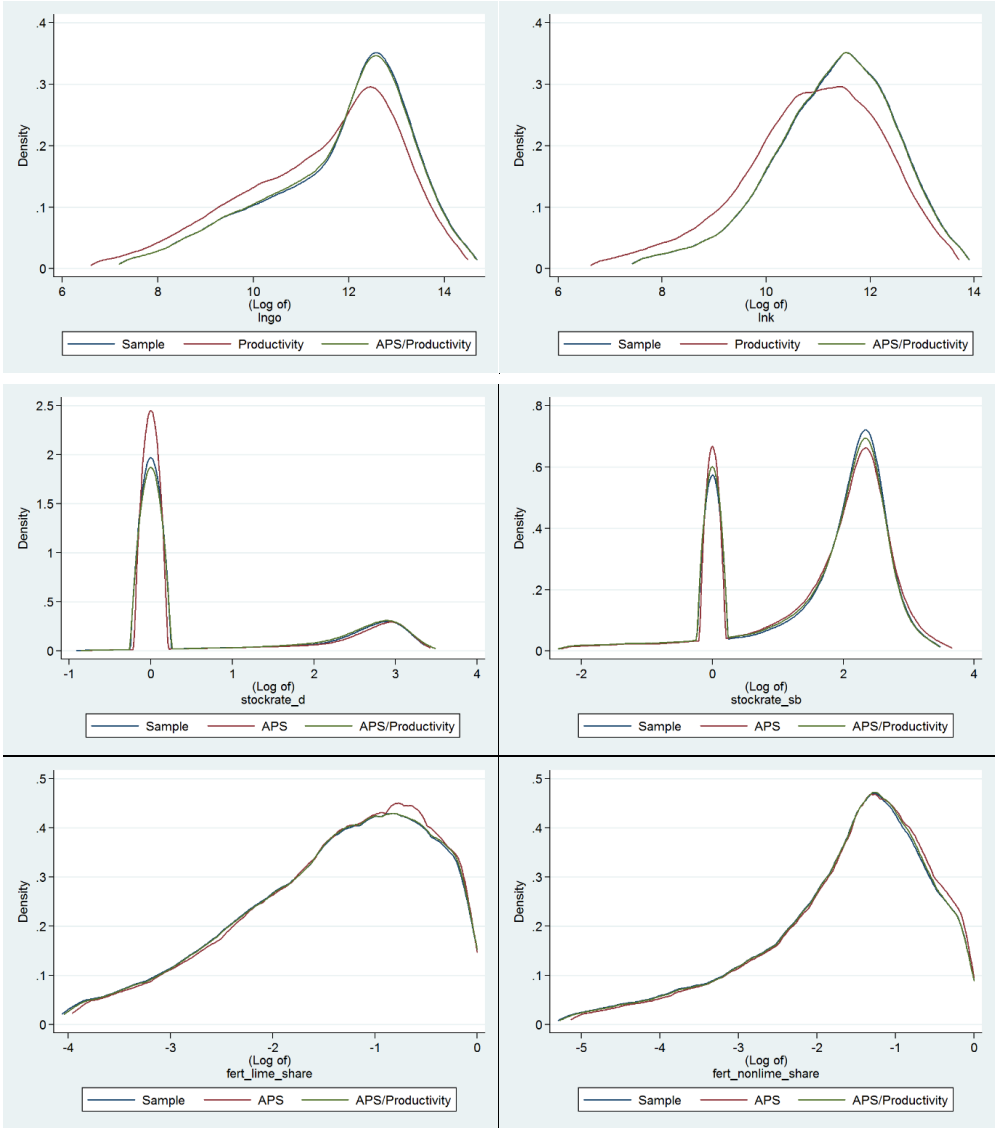

Notes: Plots exclude the top and bottom 1% of observations for confidentiality reasons. Observations for fertilizers were only from firms that had any positive application rate.

## 9.2. Appendix 2 – variables and sources

Variable	Description	Comments
Gross output	Total income adjusted for changes in stocks and excluding income from interest and dividends.	Deflated by the industry producer price index ( <i>output</i> series, 2007=100).
Capital	Sum of depreciation, rental, leasing and rates and the cost of borrowing times total fixed assets.	Deflated by the capital goods price index (not industry-specific, 2007 = 100). Cost of borrowing is set at a constant 10%, roughly the average of the business base lending rate over the period
Labour	Rolling mean count of employees, plus a headcount of working proprietors.	Not full-time equivalent (i.e. unadjusted for hours worked).
Intermediate expenditure	Purchases plus total expenses, excluding salaries and wages, bad debt write-offs, interest paid and depreciation	Deflated by the industry producer price index ( <i>input</i> series, 2007=100).
Productive land	Sum of grassland, tussock and danthonia for grazing, grain, seed & fodder crop land	Measured in hectares.
Dairy stockrates	Weighted sum of dairy units divided by total productive land	Weights - dairy cows = 7; rising = 3.5. Dummy variables equal to one were also included for firms with no dairy cows and for firms with no dairy rising.
Sheep/beef stockrates	Weighted sum of sheep/beef units divided by total productive land	Weights - Beef cows = 5; Deer = 2; Sheep = 1. Dummy variable equal to one was included for firms with no sheep/beef stock.
Produce Silage balage; Forest Harvesting	Two binary variables indicating if the firm produced any silage balage or harvested some forest	Equal to any positive amount
Fertilizer intensity	<u>Lime</u> – lime based fertilizers <u>Non-Lime</u> –nitrogen, phosphatic and potassic fertilisers (including urea, DAP and ammonium sulphate and superphosphate) <u>Effluent</u> – effluent applied	All variables are log ratios. The numerator is the sum (in tonnage) of each fertilizer group. The denominator is the sum (in hectares) of productive land. Upper limit of one was assigned to the observations (almost all firms were below this threshold). Dummy variable equal to one for firms that applied any lime-based fertilizer were also included.
Multi-firm	Variable equals to 1 if the firm has more than one KAU	
Multi-region	Variable equals to 1 if the firm operates in more than one regional council	
New entrant	Variable equals to 1 if firm has entered the market in that year	Based on status in the LBF
Exiting	Variable equals to 1 if the firm left the market in the following year	Based on LBF status. This excludes 2012 as some firm activity status data was missing for the 2013 financial year.
Flat, rolling, sloped land	Variable equals to 1 when land is in slope category A, B, or C.	Based on the meshblock nearest to the location of the geo unit.
LUC (land usage capability)	No to moderate limitations of land – 1 if land usage capability is 1, 2, or 3 (the lease limiting ones)	Some meshblocks cover a wide area, introducing measurement error if there is significant variation in weather or environmental characteristics within a meshblock

Notes: All continuous variables are measured as natural logarithms.

### 9.3. Appendix 3 – Further descriptive analysis

#### 9.3.1. (Partial) productivity trends

Figure 10 presents a number of (partial) productivity trends over 2002 and 2012. With the exception of the output-to-capital ratio, dairy records greater output for each unit of input until about 2008. From 2009, the difference between the industries reduced, and in the case of capital and intermediate expenditure, reversed. When examining each of the underlying variables constructing these ratios, we find that output was more volatile than inputs, thus the fluctuation in the ratios was largely driven by changes in quantities of agricultural product sold. This would imply that the greater fluctuation observed in the dairy industry results from this industry being more sensitive to demand shocks. However, since much of the variation appears in non-census years, the greater variation may be due to sample selection issues.

**Figure 10 – Output-to-input ratios, 2002 – 2012**

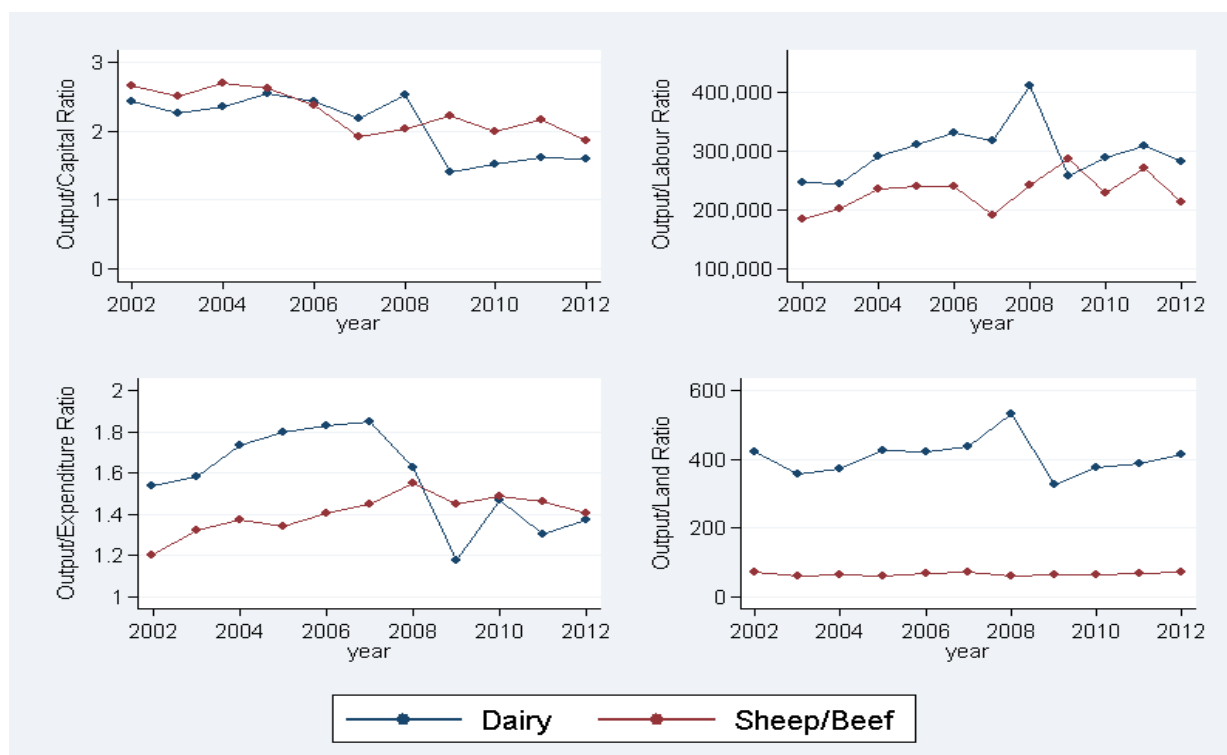

Notes: Ratios are calculated from the annual aggregates of output and inputs. Non-Census years (2003-2006, 2008-2011) should be interpreted with caution due to potential sample selection issues.

Figure 10 also shows that, while the output-to-capital ratio is at a similar level between the industries, dairy firms are able to produce a much greater output from each hectare of productive land (even after the fall in this ratio in 2009). Three possible explanations come to mind. Firstly, it is possible that

production of dairy is more reliant on the quality of land, rather than quantity, which will not be captured by the land measure but is captured in the capital measure. This explanation is supported by the larger proportion of dairy farms occupying better land classes. Second, capital also measures the quality (output potential) of other capital inputs (e.g. value of machinery, value of livestock, etc.). Third, dairy firms may utilise more non-land, non-animal capital than sheep/beef farms per hectare (e.g. buildings).

### 9.3.2. Regional trends

Figure 11 captures dairy output as a proportion of dairy and sheep/beef output in various regional councils.<sup>30</sup> Each axis refers to a different census year, with the 45 degree line marking the same ratio in both periods. This allows us to examine (graphically) changes in relative production over time, with regions above (below) the line increasing (reducing) their dairy production relative to sheep/beef. Finally, the size of each ‘bubble’ is proportional to the regional share of national dairy input in 2012.

**Figure 11 – Dairy share of regional production in dairy and sheep/beef, 2002 - 2012**

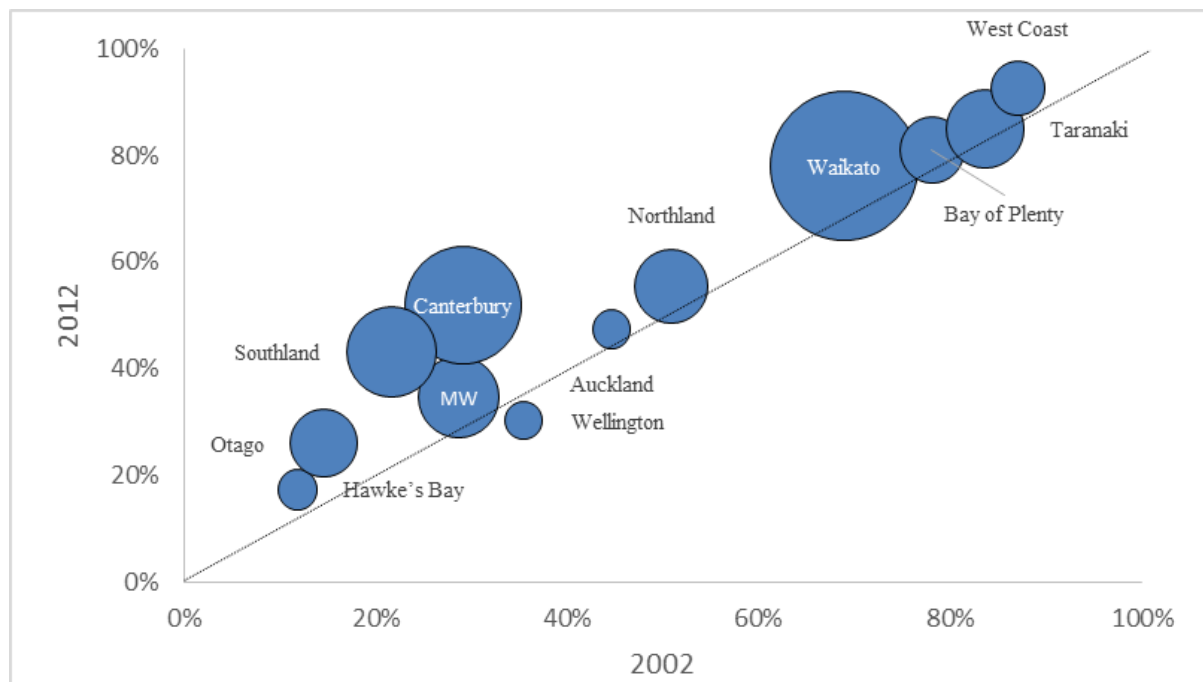

Notes: Shares calculated as dairy output produced as a proportion of dairy and sheep/beef output. Gisborne and upper South Island regions has been excluded from the sample due to small size. MW stands for Manawatu-Wanganui. Bubble size is the regional output proportion to the national.

<sup>30</sup> Based on predominant (weighted) stock, rather than specialised firms (i.e. at least 80% weighted stock), so as to capture as large a proportion of firms as possible when exploring changes in the industries.

The figure illustrates the dominance of Waikato in dairy production. This region accounted (in 2012) for just under 30% of national dairy output (in our unweighted dataset). Other large producers include the Taranaki (8%) and Manawatu-Wanganui (8%) regions in the North Island and Canterbury (17%) and Southland (10%) in the South Island. However, the most dairy-intensive regions (i.e. in terms of relative output share of dairy to sheep/beef plus dairy) in 2012 were the West Coast (93%), Taranaki (85%), and Bay of Plenty (81%). On the other hand, Hawke's Bay (17%), Wellington (30%), and Manawatu-Wanganui (35%) were more sheep/beef orientated. In terms of change, all regions other than Wellington became more dairy-based, especially in the South Island, where the larger producers increased their dairy share by 11 – 23 percentage points, compared with 1 – 9 percentage points for the larger North Island dairy producers.

In terms of output per hectare, Figure 12 (upper panel) suggests that the greatest (partial) land productivity was in the Hawke's Bay (\$490), Otago (\$460) and Canterbury (\$390) regions. In addition, these (and the West Coast) regions were the only ones to record any improvement since 2002.

In the sheep/beef industry, the largest producing regions were those in the southern South Island, accounting for almost half of national production, and the Manawatu-Wanganui region in the North Island (16%). The greatest level of output per hectare was recorded in the Auckland (\$145), Bay of Plenty (\$145), Waikato (\$125), and Southland (\$120) regions. In terms of change in land productivity, as in dairy, the large South Island producers drive the increase in productivity. However, these rates are still significantly lower than those found for dairy, confirming the industry-level differences in land productivity found in the descriptive statistics, and the (partial) productivity trends finding greater land productivity for dairy firms.

Figure 12 - Output per hectare by region and industry, 2002 and 2012

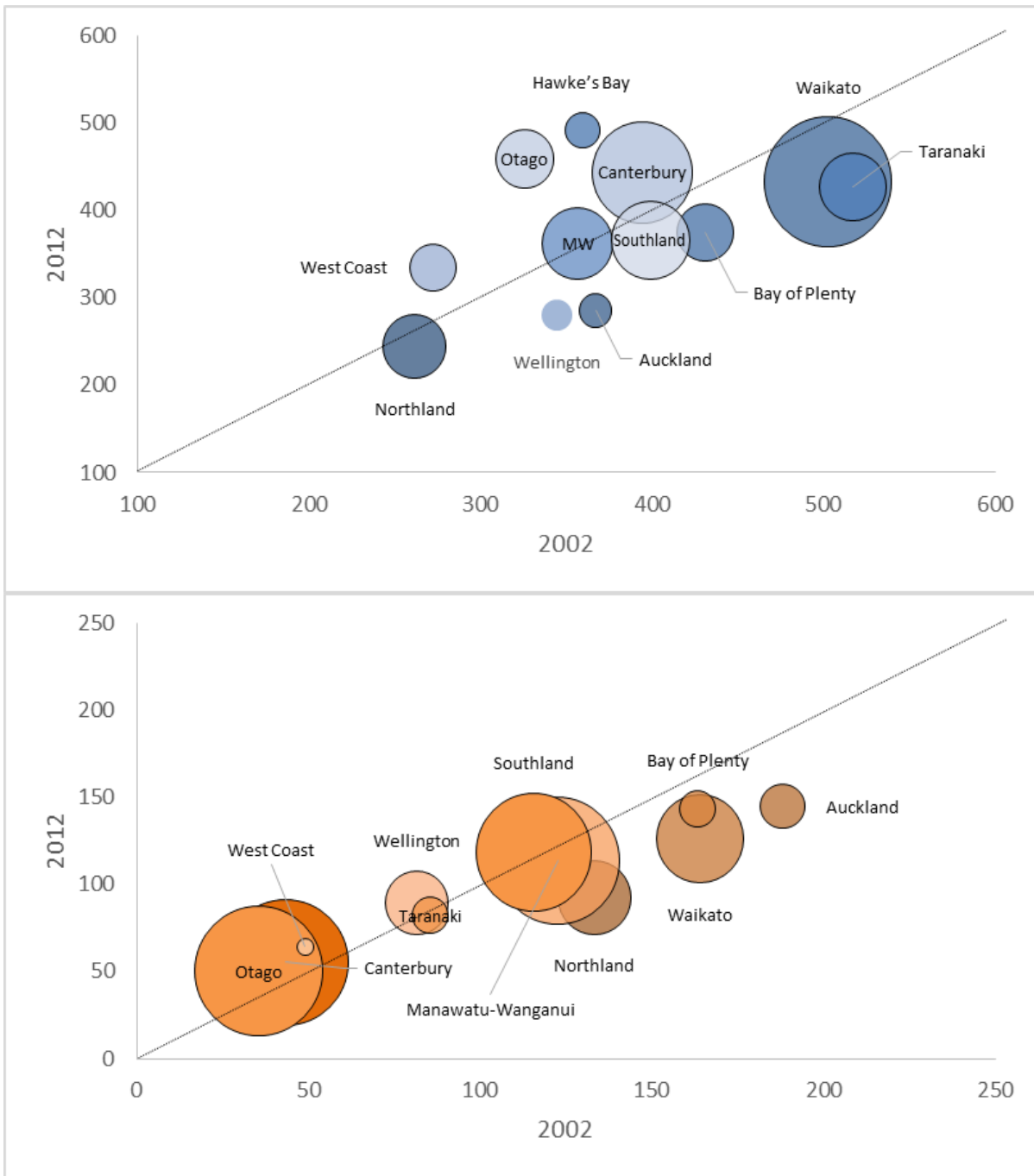

Notes: Output per hectare is calculated as the sum of output for of relevant firms, divided by the sum of all total productive land of these firms. The Upper panel refers to output per hectare in the dairy industry (blue). Lower panel refers to output per hectare in the sheep/beef industry. In both panels, the horizontal axis refers to this measure in 2002, while the vertical is 2012. The 45 degree line identifies where output per hectare was the same in both period. Bubble size refers to production in the region as a proportion of national output.

**Table 6 - Regression results, Dairy**

VARIABLES	(1)	(2)	(3)	(4)	(5)	(6)	(7)	(8)	(9)
Capital	-0.188*	-0.072	-0.055	-0.056	-0.040	-0.025	-0.005	-0.304***	-0.296***
	[0.100]	[0.193]	[0.191]	[0.191]	[0.191]	[0.189]	[0.246]	[0.058]	[0.059]
Labour	0.730***	0.401**	0.404**	0.405**	0.406**	0.384**	0.346	0.661***	0.675***
	[0.098]	[0.196]	[0.194]	[0.194]	[0.194]	[0.194]	[0.213]	[0.077]	[0.075]
Expenditure	0.655***	0.334*	0.337*	0.336*	0.325*	0.325*	0.202	0.656***	0.660***
	[0.106]	[0.181]	[0.180]	[0.180]	[0.181]	[0.182]	[0.187]	[0.036]	[0.036]
Land	0.965***	0.280	0.339	0.339	0.310	0.309	0.219	0.951***	0.953***
	[0.098]	[0.273]	[0.271]	[0.271]	[0.270]	[0.267]	[0.285]	[0.081]	[0.080]
Capital^2	0.039***	0.025***	0.024***	0.024***	0.023***	0.023***	0.026***	0.046***	0.046***
	[0.005]	[0.007]	[0.007]	[0.007]	[0.007]	[0.007]	[0.008]	[0.004]	[0.005]
Labour^2	0.030***	0.021***	0.020***	0.020***	0.020***	0.019***	0.020***	0.026***	0.027***
	[0.003]	[0.003]	[0.003]	[0.003]	[0.003]	[0.003]	[0.003]	[0.001]	[0.002]
Expenditure^2	0.047***	0.038***	0.038***	0.038***	0.038***	0.039***	0.041***	0.047***	0.046***
	[0.004]	[0.005]	[0.005]	[0.005]	[0.005]	[0.005]	[0.006]	[0.003]	[0.003]
Land^2	0.006	0.008	0.005	0.005	0.006	0.006	0.011	0.012***	0.012**
	[0.004]	[0.010]	[0.010]	[0.010]	[0.010]	[0.010]	[0.010]	[0.004]	[0.004]
Capital*Labour	-0.038***	-0.014	-0.014	-0.014	-0.015	-0.013	-0.011	-0.036***	-0.037***
	[0.008]	[0.011]	[0.011]	[0.011]	[0.011]	[0.011]	[0.012]	[0.004]	[0.005]
Capital*Expenditure	-0.050***	-0.037***	-0.037***	-0.037***	-0.037***	-0.039***	-0.040***	-0.050***	-0.050***
	[0.010]	[0.014]	[0.014]	[0.014]	[0.014]	[0.014]	[0.015]	[0.006]	[0.006]
Capital*Land	0.005	0.018	0.018	0.018	0.018	0.018	0.010	-0.001	-0.002
	[0.008]	[0.022]	[0.022]	[0.022]	[0.022]	[0.021]	[0.022]	[0.008]	[0.008]
Labour*Expenditure	-0.028***	-0.013	-0.014	-0.014	-0.014	-0.015	-0.013	-0.025***	-0.026***
	[0.009]	[0.017]	[0.016]	[0.016]	[0.016]	[0.016]	[0.018]	[0.008]	[0.008]
Labour*Land	0.030***	0.007	0.008	0.008	0.009	0.011	0.009	0.030***	0.030***
	[0.007]	[0.011]	[0.011]	[0.011]	[0.011]	[0.011]	[0.012]	[0.006]	[0.006]
Expenditure*Land	-0.084***	-0.043**	-0.042**	-0.042**	-0.041**	-0.041**	-0.032	-0.083***	-0.082***
	[0.008]	[0.019]	[0.019]	[0.019]	[0.019]	[0.019]	[0.021]	[0.007]	[0.007]
Stockrates - dairy			0.048***	0.048***	0.047***	0.045***	0.047***	0.056***	0.055***
			[0.015]	[0.015]	[0.015]	[0.015]	[0.018]	[0.010]	[0.010]
Stockrates - sheep/beef			-0.001	-0.001	-0.001	-0.001	-0.000	-0.016***	-0.016***
			[0.004]	[0.004]	[0.004]	[0.004]	[0.005]	[0.004]	[0.004]
No Sheep/Beef stock			0.007	0.007	0.006	0.007	0.003	0.040***	0.040***
			[0.011]	[0.011]	[0.011]	[0.011]	[0.012]	[0.009]	[0.009]

No Dairy rising	0.005 [0.008]	0.005 [0.008]	0.004 [0.008]	0.004 [0.008]	0.001 [0.009]	0.005 [0.005]	0.005 [0.005]
Harvested a forest		0.035 [0.029]	0.036 [0.029]	0.037 [0.028]	0.045 [0.033]	0.023 [0.037]	0.025 [0.037]
No forest		0.010 [0.010]	0.010 [0.010]	0.009 [0.010]	0.008 [0.011]	-0.010 [0.007]	-0.011 [0.007]
Produced Silage/Balage		-0.010 [0.009]	-0.012 [0.009]	-0.012 [0.009]	-0.011 [0.010]	0.013* [0.007]	0.013** [0.006]
Application rates: lime fertilizer			-0.004 [0.004]	-0.004 [0.004]	-0.004 [0.004]	-0.004 [0.002]	-0.003 [0.002]
Application rates: non-lime fertilizers			0.004 [0.004]	0.004 [0.004]	0.006 [0.005]	0.012** [0.005]	0.010** [0.005]
Application rates: effluent			0.015*** [0.006]	0.014** [0.006]	0.012** [0.006]	0.001 [0.004]	0.001 [0.004]
No lime fertilizer applied			0.011 [0.007]	0.011 [0.007]	0.012 [0.008]	0.013*** [0.004]	0.011*** [0.004]
No non-lime fertilizer applied			-0.030** [0.013]	-0.029** [0.013]	-0.026* [0.016]	-0.087*** [0.012]	-0.083*** [0.012]
No effluent applied			-0.065*** [0.017]	-0.062*** [0.017]	-0.050*** [0.018]	-0.071*** [0.012]	-0.074*** [0.013]
Multi-KAU				0.008 [0.010]	0.007 [0.010]	0.009 [0.008]	0.010 [0.008]
Multi-RC				-0.052 [0.037]	-0.059 [0.044]	-	-
Newly established firm				-0.068** [0.030]	-0.058* [0.031]	-0.048 [0.041]	-0.047 [0.040]
Exiting firm				-0.053*** [0.016]	-0.037 [0.125]	-0.081*** [0.013]	-0.080*** [0.013]
DSMD					-0.033*** [0.006]		
Rainfall (mm)					-0.028 [0.023]		
Mean annual temperature					-0.022 [0.127]		
LUC: 1-3						0.005 [0.007]	0.006 [0.007]
Slope Category: A-C						0.014**	0.014**

								[0.006]	[0.006]
Constant	1.208	5.479***	4.980**	4.988**	5.131**	5.079**		6.498***	1.780***
	[0.846]	[2.015]	[2.016]	[2.016]	[2.014]	[1.998]		[2.122]	[0.499]
Observations	22,710	22,710	22,710	22,710	22,710	22,686	18,921	21,816	21,816
Firm effect	No	Yes	Yes	Yes	Yes	Yes	Yes	No	No
Year effect	No	Yes	Yes	Yes	Yes	Yes	Yes	Yes	Yes
Regional Council effect	No	No	No	No	No	No	No	Yes	Yes
Regional Council/Year interactions	No	No	No	No	No	No	No	No	Yes
Adjusted R2	0.886	0.961	0.961	0.961	0.962	0.962	0.962	0.906	0.907
RTS at the means	1.056	0.936	1.015	1.051	0.972	0.797	0.698	0.918	0.905
SE	[0.006]	[0.032]	[0.045]	[0.057]	[0.060]	[0.080]	[0.105]	[0.074]	[0.074]
Different than zero (p-value):	0.000	0.000	0.000	0.000	0.000	0.000	0.000	0.000	0.000
Different than one (p-value):	0.000	0.048	0.740	0.381	0.640	0.011	0.004	0.290	0.220

Notes: Robust standard errors in brackets; \*\*\*  $p < 0.01$ , \*\*  $p < 0.05$ , \*  $p < 0.1$ . Observations are based on counts that have been randomly rounded to base 3 for confidentiality reasons.

**Table 7 - Regression results, Sheep/Beef**

VARIABLES	(1)	(2)	(3)	(4)	(5)	(6)	(7)	(8)	(9)
Capital	-0.250*** [0.061]	0.145 [0.109]	0.170 [0.109]	0.171 [0.109]	0.172 [0.109]	0.172 [0.109]	0.240** [0.121]	-0.247*** [0.073]	-0.247*** [0.073]
Employment	-0.022 [0.079]	-0.049 [0.117]	-0.051 [0.115]	-0.051 [0.115]	-0.052 [0.115]	-0.038 [0.115]	-0.014 [0.135]	-0.108 [0.083]	-0.102 [0.081]
Expenditure	0.701*** [0.073]	0.631*** [0.126]	0.612*** [0.127]	0.611*** [0.127]	0.612*** [0.127]	0.581*** [0.129]	0.604*** [0.144]	0.635*** [0.037]	0.635*** [0.037]
Land	0.832*** [0.046]	0.646*** [0.107]	0.716*** [0.107]	0.717*** [0.107]	0.718*** [0.107]	0.703*** [0.107]	0.676*** [0.121]	0.877*** [0.052]	0.879*** [0.052]
Capital^2	0.026*** [0.003]	0.008** [0.004]	0.008* [0.004]	0.008* [0.004]	0.008* [0.004]	0.008* [0.004]	0.008* [0.005]	0.030*** [0.004]	0.030*** [0.004]
Employment^2	0.008*** [0.002]	0.011*** [0.003]	0.010*** [0.003]	0.010*** [0.003]	0.010*** [0.003]	0.009*** [0.003]	0.010*** [0.003]	0.005* [0.003]	0.005* [0.003]
Expenditure^2	0.043*** [0.005]	0.038*** [0.006]	0.038*** [0.006]	0.038*** [0.006]	0.038*** [0.006]	0.040*** [0.006]	0.039*** [0.006]	0.048*** [0.004]	0.048*** [0.004]
Land^2	0.009*** [0.002]	0.014*** [0.004]	0.014*** [0.004]	0.014*** [0.004]	0.014*** [0.004]	0.013*** [0.004]	0.012** [0.005]	0.017*** [0.004]	0.017*** [0.004]
Capital*Employment	-0.025*** [0.006]	0.002 [0.008]	0.003 [0.007]	0.003 [0.007]	0.003 [0.007]	0.004 [0.007]	0.006 [0.008]	-0.022*** [0.005]	-0.022*** [0.005]
Capital*Expenditure	-0.025*** [0.007]	-0.024** [0.011]	-0.025** [0.011]	-0.025** [0.011]	-0.025** [0.011]	-0.027** [0.011]	-0.030*** [0.012]	-0.029*** [0.006]	-0.030*** [0.006]
Capital*Land	0.006 [0.004]	0.011 [0.008]	0.009 [0.008]	0.009 [0.008]	0.009 [0.008]	0.010 [0.008]	0.009 [0.009]	0.000 [0.006]	0.000 [0.006]
Employment*Expenditure	0.018*** [0.007]	0.004 [0.009]	0.004 [0.009]	0.004 [0.009]	0.004 [0.009]	-0.000 [0.009]	-0.003 [0.010]	0.020** [0.008]	0.019** [0.008]
Employment*Land	0.018*** [0.004]	0.007 [0.007]	0.006 [0.007]	0.006 [0.007]	0.006 [0.007]	0.007 [0.007]	0.007 [0.008]	0.019*** [0.005]	0.020*** [0.005]
Expenditure*Land	-0.078*** [0.005]	-0.076*** [0.008]	-0.075*** [0.008]	-0.075*** [0.008]	-0.075*** [0.008]	-0.075*** [0.009]	-0.068*** [0.009]	-0.083*** [0.007]	-0.083*** [0.007]
Stockrates - dairy			0.000 [0.007]	0.000 [0.007]	0.000 [0.007]	-0.000 [0.006]	-0.002 [0.007]	-0.009 [0.007]	-0.009 [0.007]
Stockrates - sheep/beef			0.121*** [0.012]	0.121*** [0.012]	0.122*** [0.012]	0.120*** [0.012]	0.119*** [0.013]	0.148*** [0.006]	0.149*** [0.007]
No Dairy stock			-0.045*** [0.015]	-0.045*** [0.015]	-0.045*** [0.015]	-0.042*** [0.015]	-0.043** [0.017]	-0.042*** [0.011]	-0.041*** [0.011]

No Dairy rising	-0.036**	-0.036**	-0.036**	-0.035**	-0.039**	-0.048***	-0.045***
	[0.018]	[0.018]	[0.018]	[0.018]	[0.020]	[0.014]	[0.013]
Harvested a forest		0.061***	0.061***	0.060***	0.056***	0.088***	0.086***
		[0.018]	[0.018]	[0.018]	[0.020]	[0.022]	[0.023]
No forest		0.007	0.007	0.006	0.005	0.018*	0.018**
		[0.009]	[0.009]	[0.009]	[0.010]	[0.008]	[0.008]
Produced Silage/Balage		-0.004	-0.003	-0.003	-0.001	-0.002	-0.002
		[0.007]	[0.007]	[0.007]	[0.008]	[0.007]	[0.007]
Application rates: lime fertilizer			-0.005	-0.005*	-0.008**	-0.002	-0.002
			[0.003]	[0.003]	[0.003]	[0.003]	[0.004]
Application rates: non-lime fertilizers			-0.005**	-0.004	-0.001	0.003	0.003
			[0.003]	[0.003]	[0.003]	[0.003]	[0.003]
Application rates: effluent			-0.010	-0.011	-0.014	0.020	0.019
			[0.015]	[0.015]	[0.016]	[0.021]	[0.021]
No lime fertilizer applied			0.019**	0.020**	0.028***	0.007	0.007
			[0.009]	[0.009]	[0.010]	[0.012]	[0.012]
No non-lime fertilizer applied			0.018*	0.018*	0.013	-0.041**	-0.040**
			[0.011]	[0.011]	[0.012]	[0.014]	[0.014]
No effluent applied			0.000	0.001	0.004	-0.159***	-0.158***
			[0.053]	[0.052]	[0.056]	[0.051]	[0.049]
Multi-KAU				-0.004	-0.005	0.001	0.001
				[0.009]	[0.010]	[0.008]	[0.008]
Multi-RC				-0.014	0.003	-	-
				[0.035]	[0.041]		
Newly established firm				-0.119***	-0.095***	-0.118***	-0.118***
				[0.027]	[0.028]	[0.026]	[0.026]
Exiting firm				-0.058***	0.072	-0.107***	-0.095***
				[0.014]	[0.238]	[0.018]	[0.016]
DSMD					-0.013**		
					[0.006]		
Rainfall (mm)					-0.046**		
					[0.021]		
Mean annual temperature					-0.040		
					[0.068]		
LUC: 1-3						0.004	0.004
						[0.007]	[0.007]
Slope Category: A-C						0.005	0.004

								[0.007]	[0.007]
Constant	0.347	-0.136	-0.667	-0.674	-0.715	-0.461	-0.389	0.476	0.524
	[0.477]	[1.043]	[1.036]	[1.036]	[1.039]	[1.044]	[1.224]	[0.369]	[0.375]
Observations	61,257	61,257	61,257	61,257	61,257	61,227	53,184	59,757	59,757
Firm effect	No	Yes	Yes	Yes	Yes	Yes	Yes	No	No
Year effect	No	Yes	Yes	Yes	Yes	Yes	Yes	Yes	Yes
Regional Council effect	No	No	No	No	No	No	No	Yes	Yes
Regional Council/Year interactions	No	No	No	No	No	No	No	No	Yes
Adjusted R2	0.891	0.952	0.953	0.953	0.953	0.953	0.954	0.896	0.896
RTS at the means	1.118	1.015	1.083	1.147	1.166	0.959	0.782	0.837	0.851
SE	[0.008]	[0.019]	[0.037]	[0.045]	[0.063]	[0.079]	[0.096]	[0.074]	[0.075]
Different than zero (p-value):	0.000	0.000	0.000	0.000	0.000	0.000	0.000	0.000	0.000
Different than one (p-value):	0.000	0.437	0.026	0.001	0.008	0.609	0.024	0.042	0.065

Notes: Robust standard errors in brackets; \*\*\*  $p < 0.01$ , \*\*  $p < 0.05$ , \*  $p < 0.1$ . Observations are based on counts that have been randomly rounded to base 3 for confidentiality reasons.

**Table 8 - Regression results, by industry and employment composition**

VARIABLES	Dairy		Sheep/beef	
	Employing firms	WP-only firms (interactions)	Employing firms	WP-only firms (interactions)
Capital	-0.215 [0.198]	0.276 [0.296]	0.237* [0.127]	-0.135 [0.178]
Labour	0.361* [0.193]	-0.141 [0.471]	0.399*** [0.113]	-1.067*** [0.271]
Expenditure	0.206 [0.189]	0.033 [0.290]	0.420*** [0.159]	0.024 [0.231]
Land	0.211 [0.232]	0.209 [0.324]	0.429*** [0.103]	0.291* [0.176]
Capital^2	0.035*** [0.008]	-0.024* [0.013]	0.001 [0.005]	0.010 [0.007]
Labour^2	0.019*** [0.002]	-0.029 [0.028]	0.020*** [0.003]	-0.025 [0.031]
Expenditure^2	0.035*** [0.008]	0.007 [0.008]	0.035*** [0.006]	0.016* [0.009]
Land^2	0.008 [0.009]	-0.007 [0.015]	0.015*** [0.004]	-0.005 [0.006]
Capital*Labour	-0.019* [0.010]	0.007 [0.033]	0.007 [0.007]	-0.006 [0.021]
Capital*Expenditure	-0.037*** [0.014]	0.008 [0.021]	-0.019* [0.010]	-0.011 [0.016]
Capital*Land	0.001 [0.016]	0.025 [0.032]	0.008 [0.008]	0.008 [0.012]
Labour*Expenditure	-0.004 [0.017]	-0.006 [0.038]	-0.023*** [0.008]	0.063*** [0.022]
Labour*Land	0.003 [0.010]	0.011 [0.037]	-0.014** [0.006]	0.045*** [0.017]
Expenditure*Land	-0.019 [0.017]	-0.033 [0.029]	-0.053*** [0.007]	-0.025* [0.013]
Stockrates - dairy	0.032*** [0.012]	0.040 [0.032]	0.001 [0.006]	-0.004 [0.017]
Stockrates - sheep/beef	-0.000 [0.004]	-0.004 [0.010]	0.090*** [0.014]	0.037** [0.018]
No Sheep/beef stock	0.008	0.000	-	-

No Dairy rising	0.007	-0.013	-0.029	-0.008
	[0.010]	[0.000]	[0.018]	[0.037]
Harvested a forest	0.031	0.022	0.049***	0.035
	[0.008]	[0.016]	[0.015]	[0.048]
No forest	0.012	-0.011	0.002	0.007
	[0.034]	[0.062]	[0.008]	[0.016]
Produced Silage/Balage	-0.009	-0.011	0.003	-0.010
	[0.011]	[0.020]	[0.007]	[0.011]
Application rates: lime fertilizer	-0.003	-0.002	-0.004	-0.005
	[0.008]	[0.018]	[0.003]	[0.007]
Application rates: non-lime fertilizers	0.006	-0.007	-0.005*	0.001
	[0.004]	[0.009]	[0.003]	[0.005]
Application rates: effluent	0.012*	0.002	-0.012	-0.004
	[0.004]	[0.009]	[0.016]	[0.035]
No lime fertilizer applied	0.004	0.015	0.019**	0.001
	[0.006]	[0.012]	[0.008]	[0.015]
No non-lime fertilizer applied	-0.010	-0.038	0.020*	-0.004
	[0.007]	[0.016]	[0.010]	[0.018]
No effluent applied	-0.052***	-0.019	0.027	-0.043
	[0.013]	[0.028]	[0.010]	[0.018]
	[0.018]	[0.031]	[0.063]	[0.101]
Multi-KAU	-0.005	0.039*	0.012	-0.030**
	[0.011]	[0.021]	[0.007]	[0.015]
Multi-RC	-0.036	-0.058	0.009	-0.046
	[0.041]	[0.065]	[0.040]	[0.054]
Newly established firm	-0.073**	0.041	-0.028	-0.135***
	[0.034]	[0.062]	[0.022]	[0.042]
Exiting firm	0.040	-0.090**	0.028	-0.084**
	[0.035]	[0.039]	[0.031]	[0.033]
WP-only firm	-	-3.049	-	-1.237
	-	[2.551]	-	[1.768]
Constant	7.545***	-	1.547	-
	[1.760]	-	[1.295]	-
Observations	22,686	-	61,227	-
Adjusted R2	0.962	-	0.953	-

Notes: Robust standard errors in brackets; \*\*\*  $p < 0.01$ , \*\*  $p < 0.05$ , \*  $p < 0.1$ . For each industry, the two columns are from the same specification, where the interaction terms presented in a separate column (second and forth) for convenience. Observations are based on counts that have been randomly rounded to base 3 for confidentiality reasons.

## 9.4. Appendix 5 – MFP trends by industry and regional council

Figure 13 – Annual changes in MFP by regional council, dairy industry

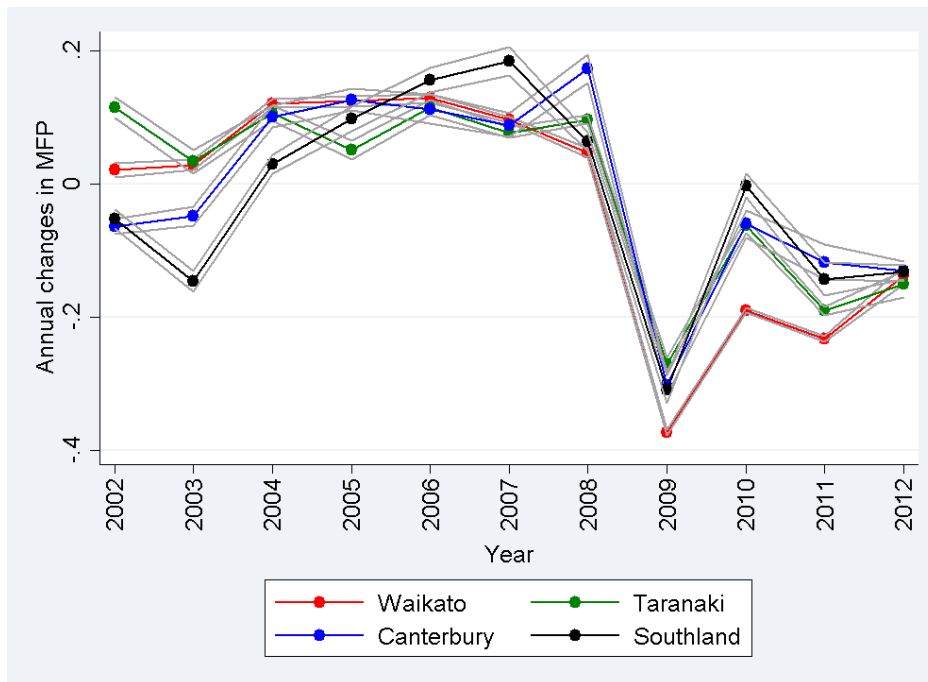

Notes: MFP is derived from equation 9 in table 6. MFP is relative to Northland region MFP in 2002, which is normalised to zero.

Figure 14 - Annual changes in MFP by regional council, sheep/beef industry

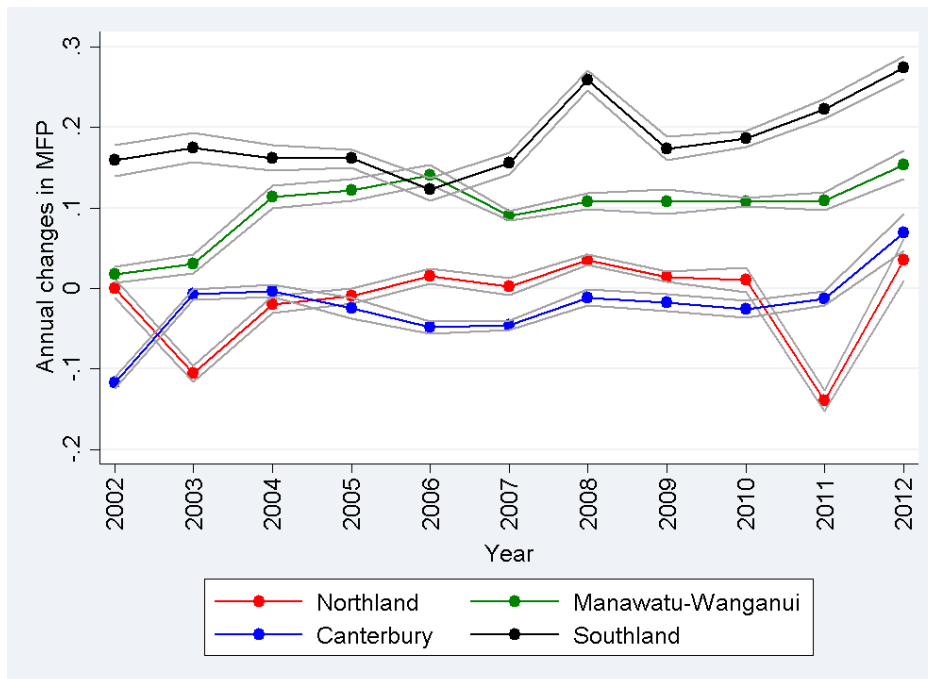

Notes: MFP is derived from equation 9 in table 6. MFP is relative to Northland region MFP in 2002, which is normalised to zero.

## Recent Motu Working Papers

All papers in the Motu Working Paper Series are available on our website [www.motu.org.nz](http://www.motu.org.nz), or by contacting us on [info@motu.org.nz](mailto:info@motu.org.nz) or +64 4 939 4250.

15-12: Laws, Athene, Jason Gush, Victoria Larsen and Adam B Jaffe. 2015. "The effect of public funding on research output: The New Zealand Marsden Fund." (forthcoming)

15-11 Dorner, Zachary and Suzi Kerr. 2015. "Methane and Metrics: From global climate policy to the NZ farm."

15-10 Grimes, Arthur and Marc Reinhardt. 2015. "Relative Income and Subjective Wellbeing: Intra-national and Inter-national Comparisons by Settlement and Country Type"

15-09 Grimes, Arthur and Sean Hyland. 2015. "A New Cross-Country Measure of Material Wellbeing and Inequality: Methodology, Construction and Results."

15-08 Jaffe, Adam and Trinh Le. 2015. "The impact of R&D subsidy of innovation: a study of New Zealand firms."

15-07 Duhon, Madeline, Hugh McDonald and Suzi Kerr. 2015 "Nitrogen Trading in Lake Taupo: An Analysis and Evaluation of an Innovative Water Management Policy.

15-06 Allan, Corey, Suzi Kerr and Campbell Will. 2015. "Are we turning a brighter shade of green? The relationship between household characteristics and greenhouse gas emissions from consumption in New Zealand" (forthcoming)

15-05 Fabling, Richard and Lynda Sanderson. 2015. "Exchange rate fluctuations and the margins of exports"

15-04 Fabling, Richard, Richard Kneller and Lynda Sanderson. 2015. "The impact of tax changes on the short-run investment behaviour of New Zealand firms"

15-03 Sin, Isabelle, Steven Stillman. 2015. "Economic Liberalisation and the Mobility of Minority Groups: Evidence for Māori in New Zealand"

15-02 Grimes, Arthur, Ian Mitchell. 2015. "Impacts of Planning Rules, Regulations, Uncertainty and Delay on Residential Property Development"

15-01 De Rassenfosse, Gaétan, and Adam B. Jaffe. 2015. "Are Patent Fees Effective at Weeding Out Low-Quality Patents?"

14-15 Sin, Isabelle, Richard Fabling, Adam Jaffe, David C. Maré and Lynda Sanderson. 2014. "Exporting, Innovation and the Role of Immigrants."

14-14 McLeod, Keith, Richard Fabling and David C. Maré. 2014. "Hiring New Ideas: International Migration and Firm Innovation in New Zealand."

14-13 Timar, Levente, Arthur Grimes and Richard Fabling. 2014. "That Sinking Feeling: The Changing Price of Disaster Risk Following an Earthquake."

14-12 Dorner, Zack, with Dean Hyslop. 2014. "Modelling Changing Rural Land Use in New Zealand 1997 to 2008 Using a Multinomial Logit Approach."

14-11 Grimes, Arthur, Eyal Apatov, Larissa Lutchman and Anna Robinson. 2014. "Infrastructure's Long-Lived Impact on Urban Development: Theory and Empirics."

14-10 Maré, David C., Lynda Sanderson and Richard Fabling. 2014. "Earnings and Employment in Foreign-owned Firms."

14-09 Kerr, Suzi, and Vicki Duscha. 2014. "Going to the Source: Using an Upstream Point of Regulation for Energy in a National Chinese Emissions Trading System."